

# 작업공정사진철

고객명: (주)

공사명: AC MOTOR REWINDING

규격: AC 440V 145KW 8P

REPAIR 내역: 분해 및 불순물 CLEANSING DRYING  
STATOR REWINDING  
INSULATING VARNISH DIPPING DRYING  
반 부하측 HOUSING METALLIZING 연마  
BALANCING실시 및 UNBALANCE교정  
입 출고검사 및 COLOR PAINTING



<http://jinyangmotor.com/>



JIN YANG

# 작업 공정 사진

작업공정

AC MOTOR 145KW 8P 입고검사



Ass'y

분해 전

작업공정

AC MOTOR 145KW 8P 입고검사

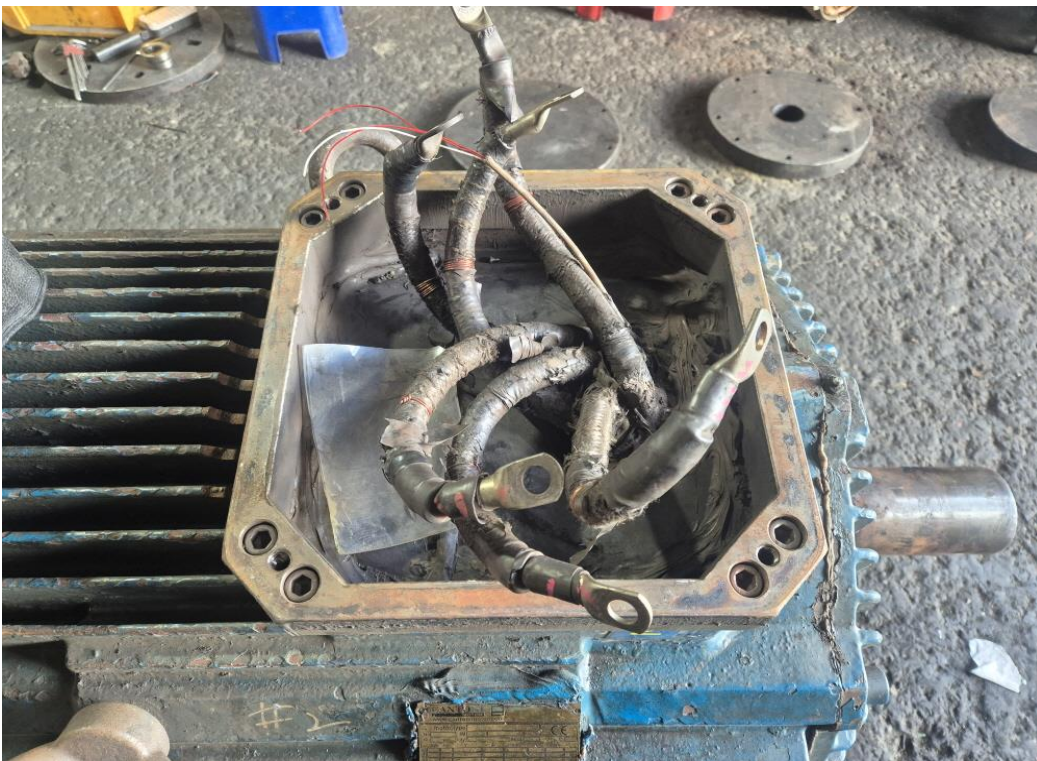

권선검사

POWER LINE 이상

JIN YANG

# 작업 공정 사진

작업공정

AC MOTOR 145KW 8P 입고검사



분해 실시

BOLT 터짐

작업공정

AC MOTOR 145KW 8P 입고검사



분해후 권체

권선부

JIN YANG

# 작업 공정 사진

작업공정

AC MOTOR 145KW 8P 입고검사



STATOR 권체

세척 후

작업공정

AC MOTOR 145KW 8P 입고검사



STATOR 권선

권선 손상부

JIN YANG

### 작업 공정 사진

작업공정

AC MOTOR 145KW 8P 입고검사

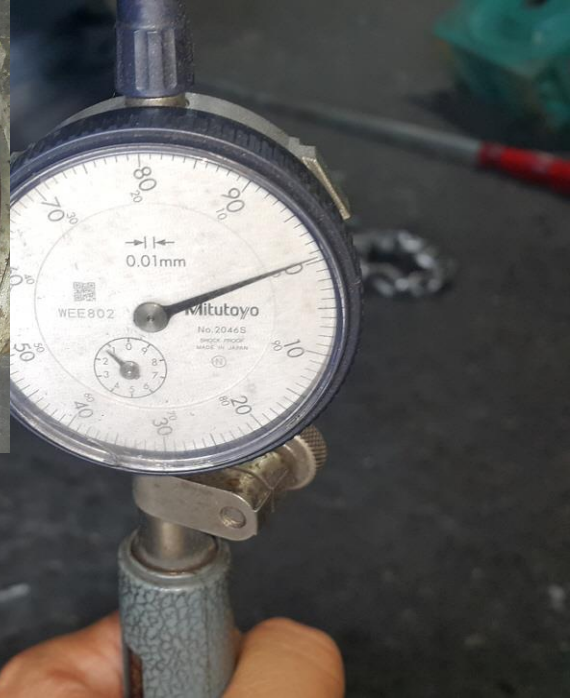

BRACKET

부하측 HOUSING 검사 0/100로 양호

작업공정

AC MOTOR 145KW 8P 입고검사



BRACKET

반 부하측 HOUSING 검사 5/100으로 불량

JIN YANG

# 작업 공정 사진

작업공정

AC MOTOR 145KW 8P REWINDING

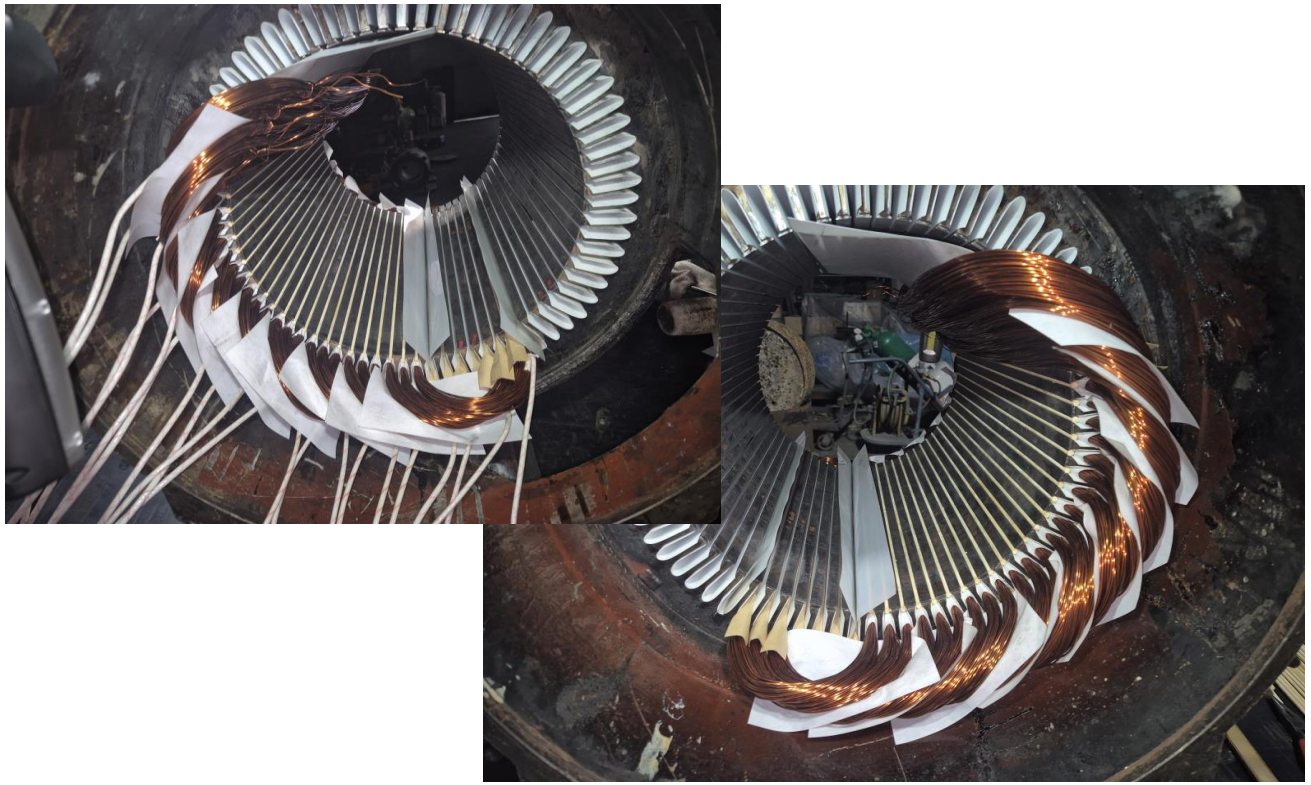

STATOR 권체

재 권선 실시

작업공정

AC MOTOR 145KW 8P REWINDING



STATOR 권체

재 권선 실시 후

JIN YANG

# 작업 공정 사진

작업공정

AC MOTOR 145KW 8P REWINDING



STATOR 권체

결선 및 BANDING 실시 후

작업공정

AC MOTOR 145KW 8P REWINDING



STATOR 권체

1, 2차 INSULATING VARNISH DIPPING DRYING 실시

JIN YANG

# 작업 공정 사진

작업공정

AC MOTOR 145KW 8P REWINDING



STATOR 권체

절연건조 실시 후

작업공정

AC MOTOR 145KW 8P REWINDING



BRACKET

반 부하측 HOUSING METALLIZING 연마 후 검사 0/100

JIN YANG

# 작업 공정 사진

작업공정

AC MOTOR 145KW 8P REWINDING

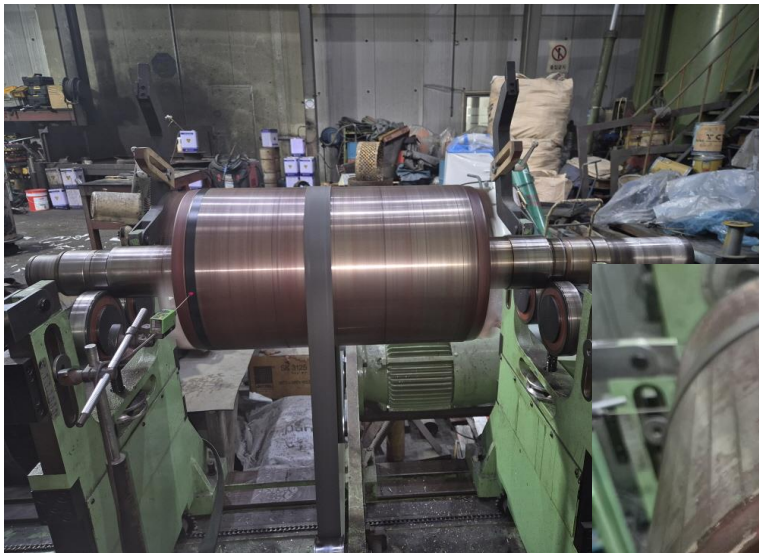

ROTOR

BALANCING실시 및 UNBALANCE교정

작업공정

AC MOTOR 145KW 8P REWINDING



교정전

교정 후



교정 MONITORING

교정된 UNBALANCE REPORT 참조

JIN YANG

# 작업 공정 사진

작업공정

AC MOTOR 145KW 8P REWINDING

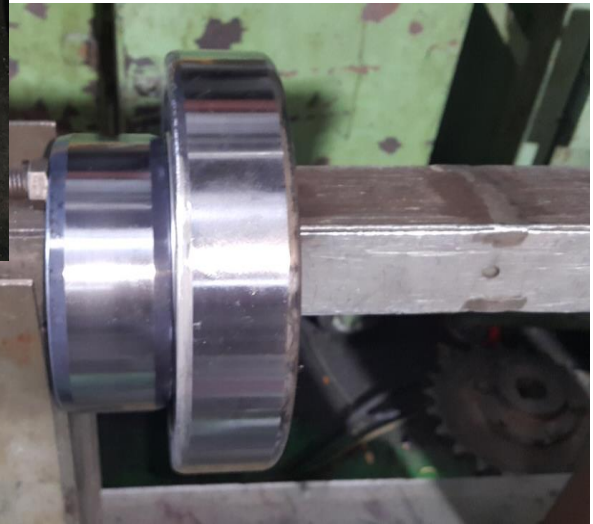

소모부품

교환될 BEARING 예열실시

작업공정

AC MOTOR 145KW 8P REWINDING



ROTOR

BEARING 예열교환 및 GREASE CHARGING 조립실시

JIN YANG	작업 공정 사진
----------	----------

작업공정	AC MOTOR 145KW 8P REWINDING
------	-----------------------------



FAN COVER 고정 BLOCK 가공설치



GREASE CHARGING구 설치

조립부품	파손된 조립부품 복원 후
------	---------------

작업공정	AC MOTOR 145KW 8P REWINDING
------	-----------------------------



POWER	POWER LINE 불순물 유입방지 PAD 복원 후
-------	------------------------------

	PT-100Ω TEMPERATURE SENSOR 설치
--	-------------------------------

JIN YANG

작업 공정 사진

작업공정

AC MOTOR 145KW 8P REWINDING



출고검사

△일때 각 상별 절연저항 & 권선저항

작업공정

AC MOTOR 145KW 8P REWINDING



출고검사

시운전 TEST 실시

JIN YANG

작업 공정 사진

작업공정

AC MOTOR 145KW 8P REWINDING



출고검사

시운전 TEST 실시  $\Delta$ 일때 운전 CURRENT

작업공정

AC MOTOR 145KW 8P REWINDING



출고검사 후

COLOR PAINTING

# BALANCING INSPECTION REPORT

SETUP

PROJECT NO: AC ROTOR 8P	
CUSTOMER : NO : 0 TYPE : 0 OPERATOR : 0	
PART NAME : AC ROTOR	TEST TIME : 2026.06.02 09:38:43
GRADE : G6.3	RATING SPEED : 900 rpm
WEIGHT : 332.000 kg	TESTING SPEED : 505 rpm
RADIUS : 128 mm 128 mm	CORRECTION : ADD
ACCEPTABLE UNBALANCE(Unit:g)	
PLANE1 : 87.000	PLANE2 : 87.000

INITIAL UNBALANCE

	PLANE1	PLANE2
UNBALANCE	10.900 g	34.500 g
ANGLE	107 deg	344 deg
RESULT	OK	OK

CORRECT UNBALANCE

	PLANE1	PLANE2
UNBALANCE	12.100 g	8.400 g
ANGLE	118 deg	219 deg
RESULT	OK	OK

CORRECT UNBALANCE GRAPH( max = 50.0 g )

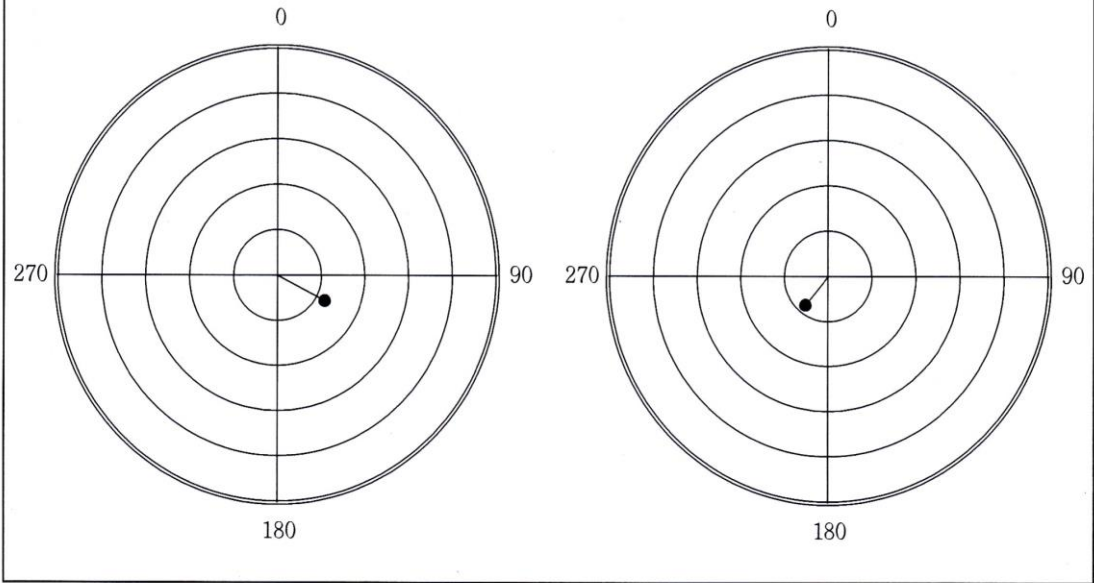

진양전기  
 경남 창원시 마산회원구 내서읍 증리공단로3길 17-2  
 TEL : 055-231-9318 FAX : 055-231-9314  
 E-mail : jinyang2913@naver.com