

# 작업공정사진철

고객명: (주)  
공사명: 풍력공장 OHC(TEFO) MOTOR 예방정비

규격: 권선형 440V 60HP 8P 60%ED 외 3대

REPAIR 내역: 분해 조립 및 불순물 CLEANSING DRYING  
INSULATING VARNISH DIPPING DRYING  
부하측 HOUSING METALLIZING 연마 1면  
BALANCING작업 UNBALANCE교정  
BEARING 및 BRUSH교환  
입 출고검사 시운전 TEST



<http://jinyangmotor.com/>



JIN YANG

# 작업 공정 사진

작업공정

권선형 MOTOR 60HP 8P 외 4대 입고검사



Ass'y

불순물제거 스팀세척 후 분해 실시

작업공정

권선형 MOTOR 60HP 8P 외 4대 입고검사



BRACKET

MAIN 부하측 HOUSING 검사 5/100으로 불량

JIN YANG

# 작업 공정 사진

작업공정

권선형 MOTOR 60HP 8P 외 3대 OVERHAUL

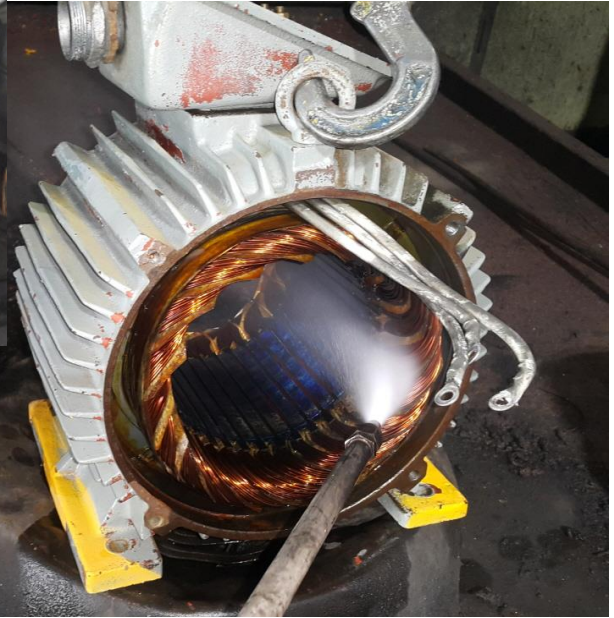
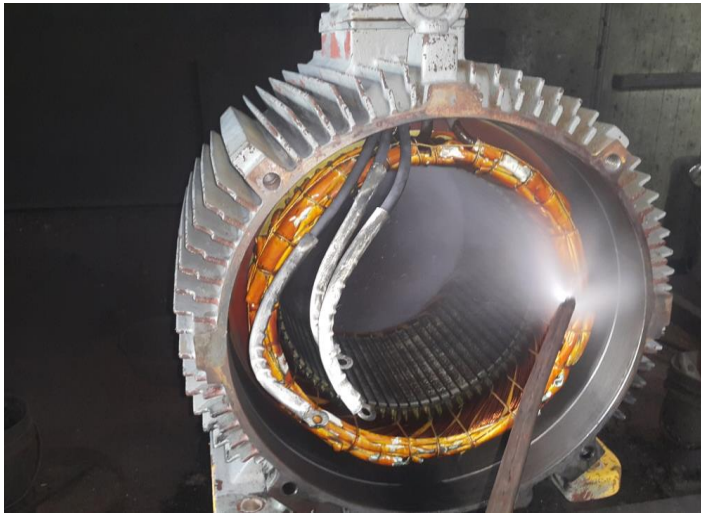

STATOR 권체

스팀세척 실시





작업공정

권선형 MOTOR 60HP 8P 외 3대 OVERHAUL



ROTOR 권체

스팀세척 실시

JIN YANG	작업 공정 사진
작업공정	권선형 MOTOR 60HP 8P 외 3대 OVERHAUL
	
권체	세척 후 권선상태 양호
작업공정	권선형 MOTOR 60HP 8P 외 3대 OVERHAUL
	
조립부품	세척 실시

JIN YANG

# 작업 공정 사진

작업공정

권선형 MOTOR 60HP 8P 외 3대 OVERHAUL



권체

세척 후 건조실시

작업공정

권선형 MOTOR 60HP 8P 외 3대 OVERHAUL



BRACKET

MAIN 부하측 HOUSING METALLIZING 연마 후 검사 0/100

JIN YANG

# 작업 공정 사진

작업공정

권선형 MOTOR 60HP 8P 외 3대 OVERHAUL

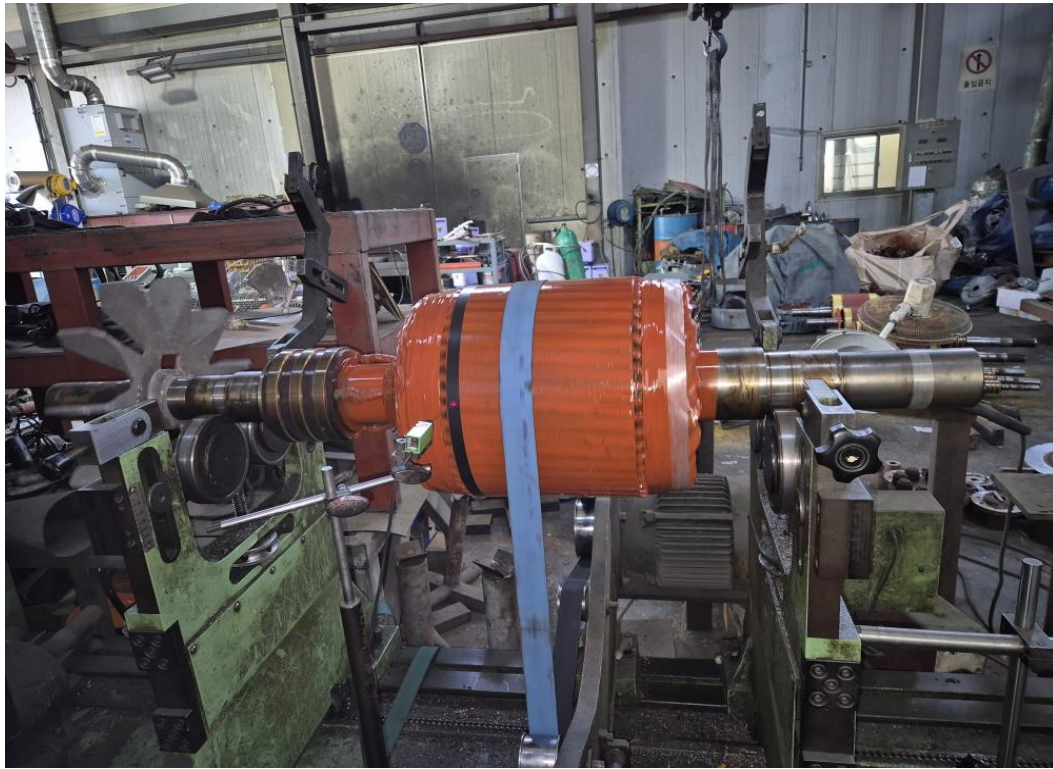

ROTOR 권체

BALANCING 실시

작업공정

권선형 MOTOR 60HP 8P 외 3대 OVERHAUL



ROTOR

초기 UNBALANCE

JIN YANG

# 작업 공정 사진

작업공정

권선형 MOTOR 60HP 8P 외 3대 OVERHAUL



ROTOR

교정된 UNBALANCE REPORT 참조

작업공정

권선형 MOTOR 60HP 8P 외 3대 OVERHAUL



소모품

취외 & 교환 될 BEARING 4대분

JIN YANG

# 작업 공정 사진

작업공정

권선형 MOTOR 60HP 8P 외 3대 OVERHAUL

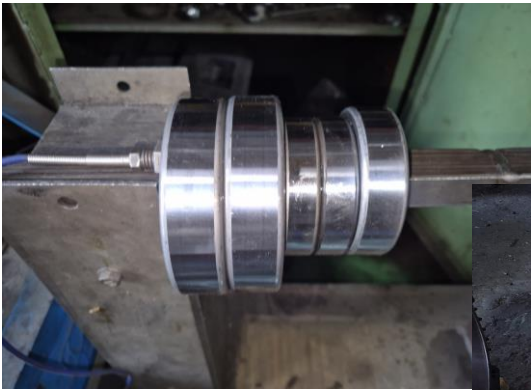

소모품

BEARING 예열교환 조립실시

작업공정

권선형 MOTOR 60HP 8P 외 3대 OVERHAUL

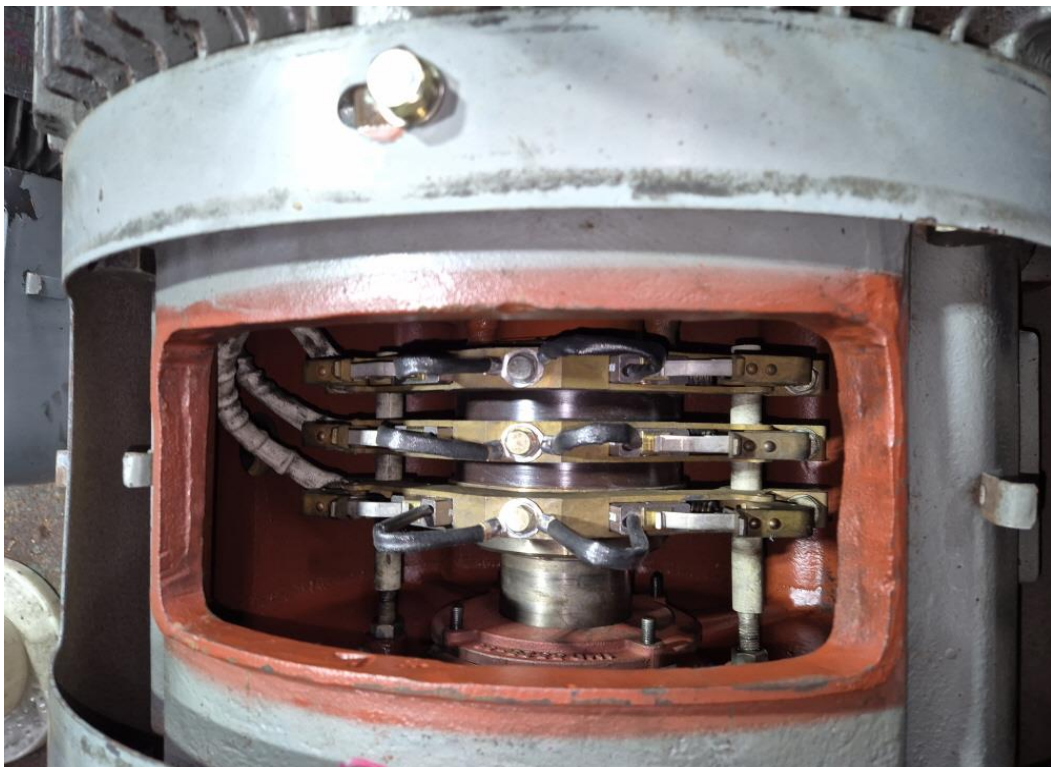

Ass'y 조립

BRUSH교환 실시

JIN YANG

# 작업 공정 사진

작업공정

권선형 MOTOR 60HP 8P 외 3대 OVERHAUL



출고검사 MAIN

1차 절연저항 & 각 상별 권선저항

작업공정

권선형 MOTOR 60HP 8P 외 3대 OVERHAUL



출고검사 MAIN

2차 절연저항 & 각 상별 권선저항

JIN YANG

# 작업 공정 사진

작업공정

권선형 MOTOR 60HP 8P 외 3대 OVERHAUL

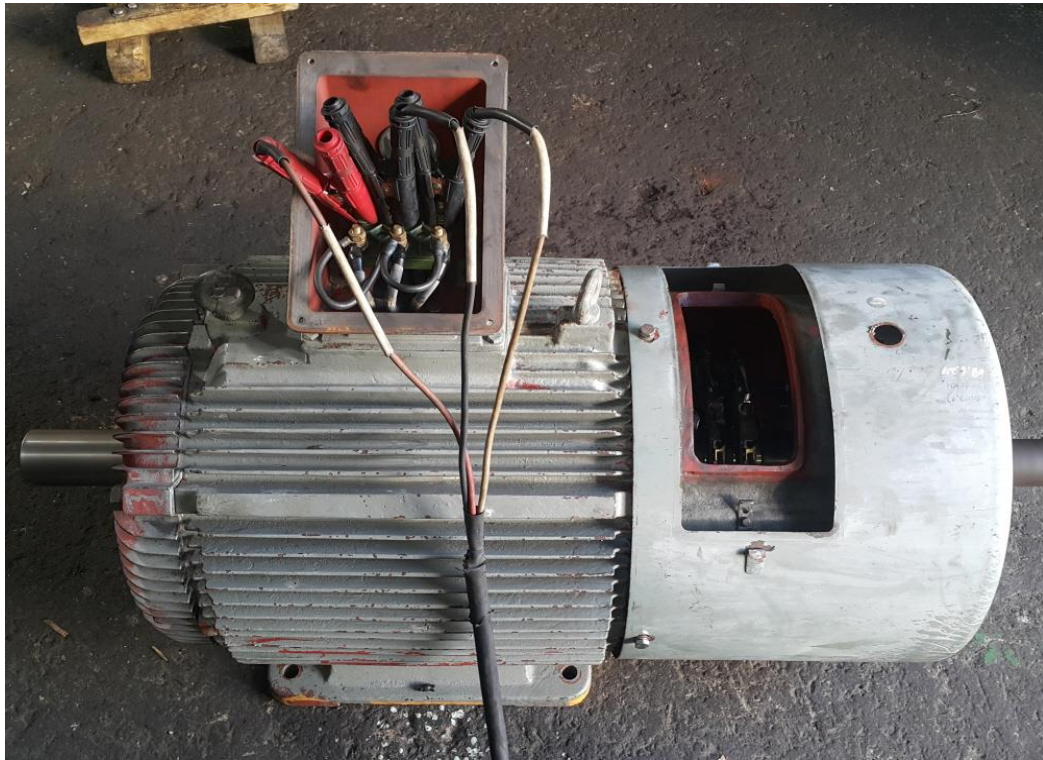

출고검사 MAIN

시운전 TEST 실시



작업공정

권선형 MOTOR 60HP 8P 외 3대 OVERHAUL



출고검사 MAIN

시운전 TEST 실시 운전 CURRENT

JIN YANG	작업 공정 사진
작업공정	권선형 MOTOR 60HP 8P 외 3대 OVERHAUL
	
출고검사 MAIN	441V일때 2차 출력 전압
작업공정	권선형 MOTOR 60HP 8P 외 3대 OVERHAUL
	
Ass'y	출고검사 후

# BALANCING INSPECTION REPORT

## SETUP

PART NAME : TEF-0 MAIN ROTOR 8P			
CUSTOMER : (주)			
TEST TIME : 2025. 5.12 10:42:22			
GRADE	: G 6.3	RATING SPEED	: 900 rpm
WEIGHT	: 254.000 kg	TESTING SPEED	: 439 rpm
DIAMETER	: 350 mm	CORRECTION	: ADD
ACCEPTABLE UNBALANCE			
PLANE1	: 49.9 gr	PLANE2	: 49.9 gr

## INITIAL UNBALANCE

	PLANE1	PLANE2
UNBALANCE	209.0 gr	18.2 gr
ANGLE	29 deg	58 deg
RESULT	REJECT	ACCEPT

## CORRECT UNBALANCE

	PLANE1	PLANE2
UNBALANCE	11.7 gr	12.0 gr
ANGLE	45 deg	159 deg
RESULT	ACCEPT	ACCEPT

CORRECT UNBALANCE GRAPH (max = 50.0 gr )

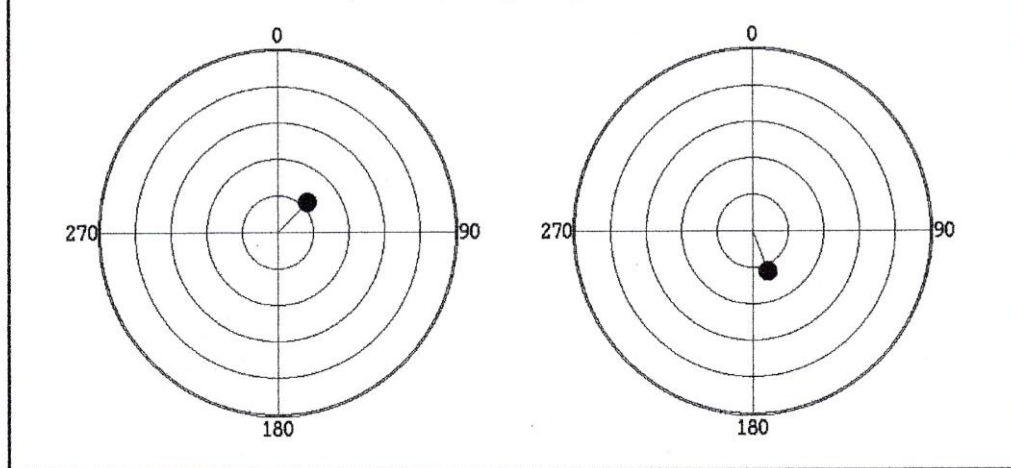

진양전기  
 경남 마산시 내서읍 중리 1123-3번지  
 TEL (055) - 231-9318-9  
 FAX (055) - 231-9314

Jinwon Balancing Machine

Jinwon Engineering (053) 354-7387