

# 작업공정사진철

고객명: (주)

공사명: 원자력공장 100톤 OHC(TE31)MOTOR 예방정비

규격: 권선형 440V 60HP 6P 60%ED 외 4대

REPAIR 내역: 분해 조립 및 불순물 CLEANSING DRYING  
INSULATING VARNISH DIPPING DRYING  
HOUSING 보수 5EA  
BALANCING작업 UNBALANCE교정  
BEARING 교환  
입 출고검사 시운전 TEST 및 COLOR PAINTING



<http://jinyangmotor.com/>



JIN YANG	작업 공정 사진
----------	----------

작업공정	권선형 MOTOR 60HP 6P 의 4대 OVERHAUL
------	---------------------------------



출고검사 60HP	STATOR 절연저항 & 각 상별 권선저항
-----------	-------------------------

작업공정	권선형 MOTOR 60HP 6P 의 4대 OVERHAUL
------	---------------------------------



출고검사 60HP	시운전 TEST 실시
-----------	-------------

JIN YANG	작업 공정 사진
----------	----------

작업공정	권선형 MOTOR 60HP 6P 외 4대 OVERHAUL
------	---------------------------------



출고검사 60HP	시운전 TES실시 운전 CURRENT
-----------	----------------------

작업공정	권선형 MOTOR 60HP 6P 외 4대 OVERHAUL
------	---------------------------------



출고검사 50HP	절연저항 & 각 상별 권선저항
-----------	------------------

JIN YANG	작업 공정 사진
----------	----------

작업공정	권선형 MOTOR 60HP 6P 외 4대 OVERHAUL
------	---------------------------------



출고검사 50HP	시운전 TEST 실시 운전 CURRENT
-----------	------------------------

작업공정	권선형 MOTOR 60HP 6P 외 4대 OVERHAUL
------	---------------------------------



출고검사 15HP	주행 No1 절연저항 & 각 상별 권선저항
-----------	-------------------------

JIN YANG	작업 공정 사진
----------	----------

작업공정	권선형 MOTOR 60HP 6P 외 4대 OVERHAUL
------	---------------------------------



출고검사 15HP	주행 No1 시운전 TEST 실시 운전 CURRENT
-----------	-------------------------------

작업공정	권선형 MOTOR 60HP 6P 외 4대 OVERHAUL
------	---------------------------------



출고검사 15HP	주행 No2 절연저항 & 각 상별 권선저항
-----------	-------------------------

JIN YANG	작업 공정 사진
----------	----------

작업공정	권선형 MOTOR 60HP 6P 외 4대 OVERHAUL
------	---------------------------------



출고검사 15HP	주행 No2 시운전 TEST 실시 운전 CURRENT
-----------	-------------------------------

작업공정	권선형 MOTOR 60HP 6P 외 4대 OVERHAUL
------	---------------------------------

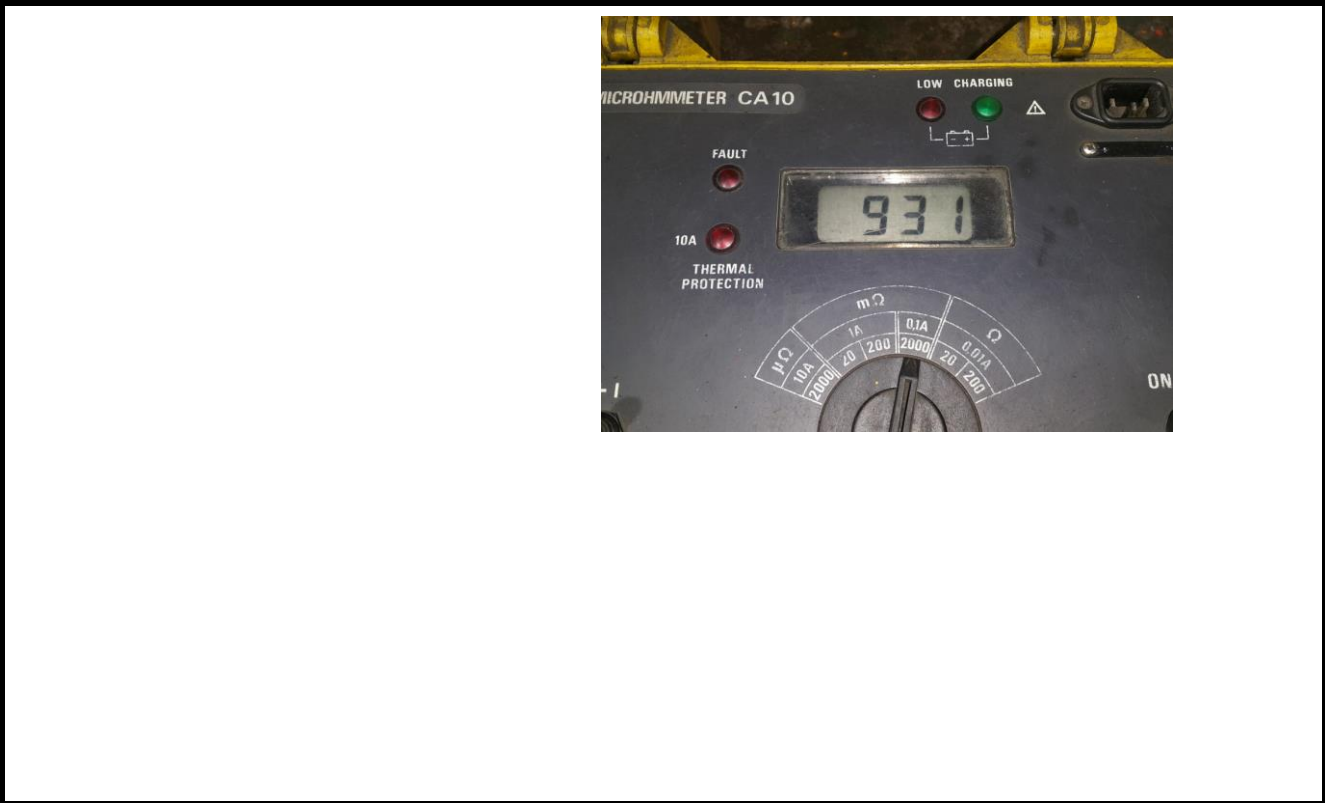

출고검사 15HP	회행 절연저항 & 각 상별 권선저항
-----------	---------------------

JIN YANG	작업 공정 사진
작업공정	권선형 MOTOR 60HP 6P 외 4대 OVERHAUL
출고검사 15HP	횡행 시운전 TEST 실시 운전 CURRENT
작업공정	권선형 MOTOR 60HP 6P 외 4대 OVERHAUL
출고검사 15HP	횡행 BRAKE 시운전 TEST 실시 운전 CURRENT
이외 DATA는 CHECK LIST 참조 하십시오	

JIN YANG	작업 공정 사진
----------	----------

작업공정	권선형 MOTOR 60HP 6P 외 4대 OVERHAUL
------	---------------------------------



출고검사 후	COLOR PAINTING
--------	----------------

작업공정	권선형 MOTOR 60HP 6P 외 4대 OVERHAUL
------	---------------------------------



출고검사 후	COLOR PAINTING
--------	----------------

<http://jinyangmotor.com/>





# BALANCING INSPECTION REPORT

## SETUP

PART NAME : 권선형 ROTOR 15HP 1	
CUSTOMER :	
TEST TIME : 2025. 4. 3 8:38:16	
GRADE : G 6.3	RATING SPEED : 1200 rpm
WEIGHT : 62.000 kg	TESTING SPEED : 511 rpm
DIAMETER : 120 mm	CORRECTION : ADD
ACCEPTABLE UNBALANCE	
PLANE1 : 13.0 gr	PLANE2 : 13.0 gr

## INITIAL UNBALANCE

	PLANE1	PLANE2
UNBALANCE	21.6 gr	25.4 gr
ANGLE	85 deg	335 deg
RESULT	REJECT	REJECT

## CORRECT UNBALANCE

	PLANE1	PLANE2
UNBALANCE	12.7 gr	5.9 gr
ANGLE	294 deg	139 deg
RESULT	ACCEPT	ACCEPT

CORRECT UNBALANCE GRAPH (max = 50.0 gr )

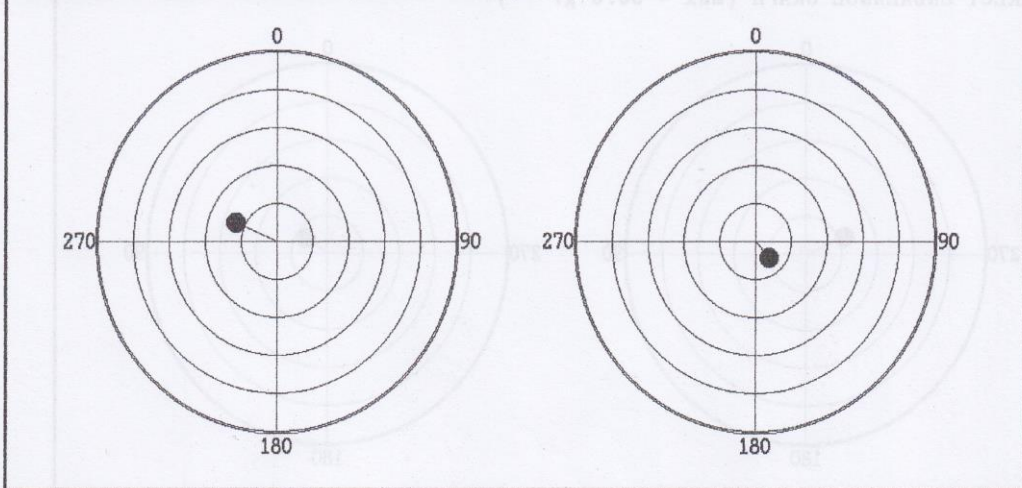

진 양 전 기  
 경남 마산시 내서읍 중리 1123-3번지  
 TEL (055) - 231-9318-9  
 FAX (055) - 231-9314

# BALANCING INSPECTION REPORT

## SETUP

PART NAME : 권선형 ROTOR 15HP 2		RATING SPEED : 1200 rpm	
CUSTOMER :		TESTING SPEED : 509 rpm	
TEST TIME : 2025. 4. 3 7:57:26		CORRECTION : ADD	
GRADE : G 6.3	WEIGHT : 62.000 kg	DIAMETER : 120 mm	
ACCEPTABLE UNBALANCE		PLANE1 : 13.0 gr	PLANE2 : 13.0 gr

## INITIAL UNBALANCE

	PLANE1	PLANE2
UNBALANCE	15.3 gr	25.8 gr
ANGLE	176 deg	7 deg
RESULT	REJECT	REJECT

## CORRECT UNBALANCE

	PLANE1	PLANE2
UNBALANCE	11.8 gr	7.4 gr
ANGLE	293 deg	56 deg
RESULT	ACCEPT	ACCEPT

CORRECT UNBALANCE GRAPH (max = 50.0 gr )

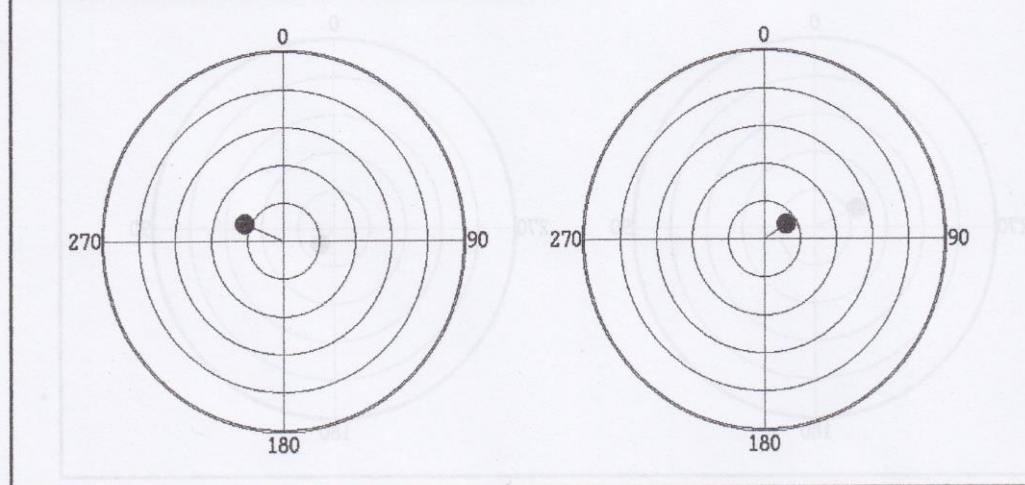

진양전기  
 경남 마산시 내서읍 중리 1123-3번지  
 TEL (055) - 231-9318-9  
 FAX (055) - 231-9314

# BALANCING INSPECTION REPORT

## SETUP

PART NAME : 권선형 ROTOR 15HP형행			
CUSTOMER :			
TEST TIME : 2025. 4. 3 9:15:53			
GRADE :	G 6.3	RATING SPEED :	1200 rpm
WEIGHT :	62.000 kg	TESTING SPEED :	510 rpm
DIAMETER :	120 mm	CORRECTION :	ADD
ACCEPTABLE UNBALANCE		PLANE2 :	
PLANE1 :	13.0 gr		13.0 gr

## INITIAL UNBALANCE

	PLANE1	PLANE2
UNBALANCE	8.5 gr	4.0 gr
ANGLE	162 deg	350 deg
RESULT	ACCEPT	ACCEPT

## CORRECT UNBALANCE

	PLANE1	PLANE2
UNBALANCE	8.5 gr	4.0 gr
ANGLE	162 deg	350 deg
RESULT	ACCEPT	ACCEPT

CORRECT UNBALANCE GRAPH (max = 10.0 gr )

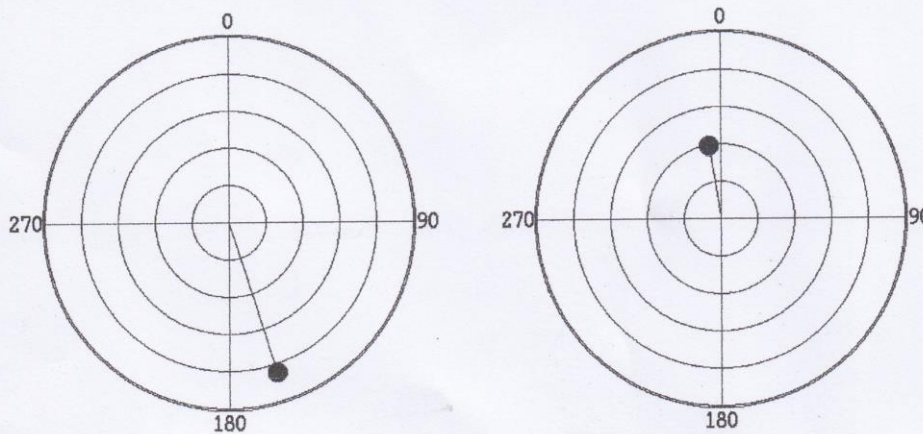

진양전기  
 경남 마산시 내서읍 중리 1123-3번지  
 TEL (055) - 231-9318-9  
 FAX (055) - 231-9314

TEST TIME : 2025. 4. 3 7:18:23	
GRADE : G 6.3	RATING SPEED : 1200 rpm
WEIGHT : 146.000 kg	TESTING SPEED : 515 rpm
DIAMETER : 310 mm	CORRECTION : ADD
ACCEPTABLE UNBALANCE	
PLANE1 : 24.4 gr	PLANE2 : 24.4 gr

**INITIAL UNBALANCE**

	PLANE1	PLANE2
UNBALANCE	24.6 gr	17.6 gr
ANGLE	22 deg	48 deg
RESULT	REJECT	ACCEPT

**CORRECT UNBALANCE**

	PLANE1	PLANE2
UNBALANCE	10.6 gr	4.7 gr
ANGLE	338 deg	35 deg
RESULT	ACCEPT	ACCEPT

CORRECT UNBALANCE GRAPH (max = 50.0 gr )

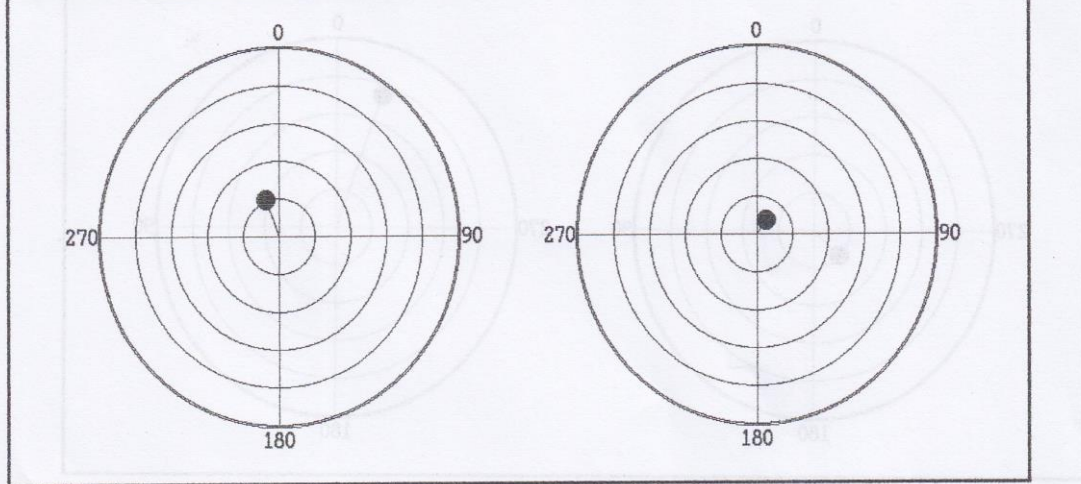

진양전기  
 경남 마산시 내서읍 중리 1123-3번지  
 TEL (055) - 231-9318-9  
 FAX (055) - 231-9314