

# 작업공정 REPORT

고객명: (주)

공사명: 한울원전 1호기 터빈홀 Main Crane Motor 정비 1호기 AUX

규격: 권선형 460V 100HP 6P 60%ED

REPAIR 내역: 분해 조립 및 불순물 CLEANSING DRYING  
STATOR REWINDING  
INSULATING VARNISH DIPPING DRYING  
부하측 HOUSING METALLIZING 연마  
BALANCING작업 UNBALANCE교정  
BEARING 교환  
입 출고검사 시운전 TEST 및 COLOR PAINTING



<http://jinyangmotor.com/>



JIN YANG

# 작업 공정 사진

작업공정

권선형 MOTOR 100HP 6P REWINDING

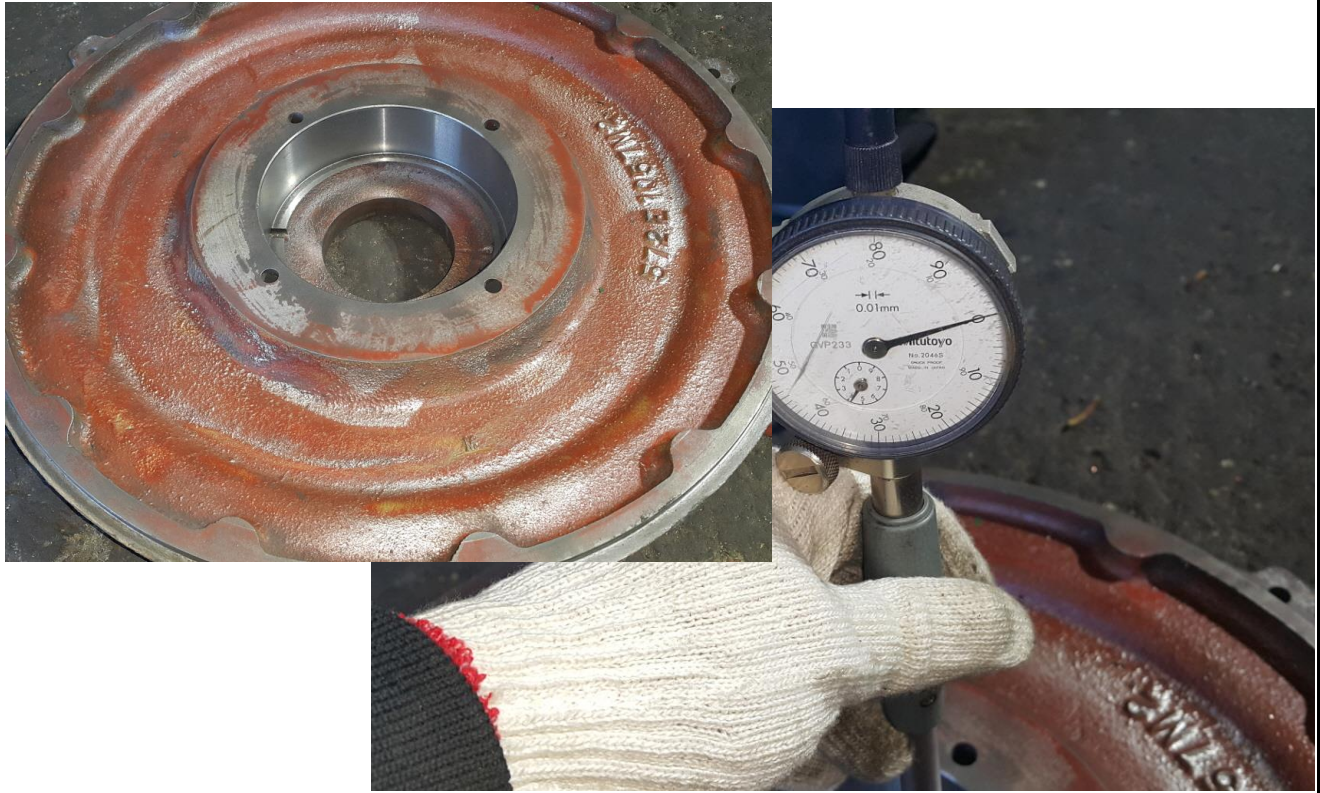

BRACKET

부하측 HOUSING METALLIZING 연마 후 검사 0/100

작업공정

권선형 MOTOR 100HP 6P REWINDING

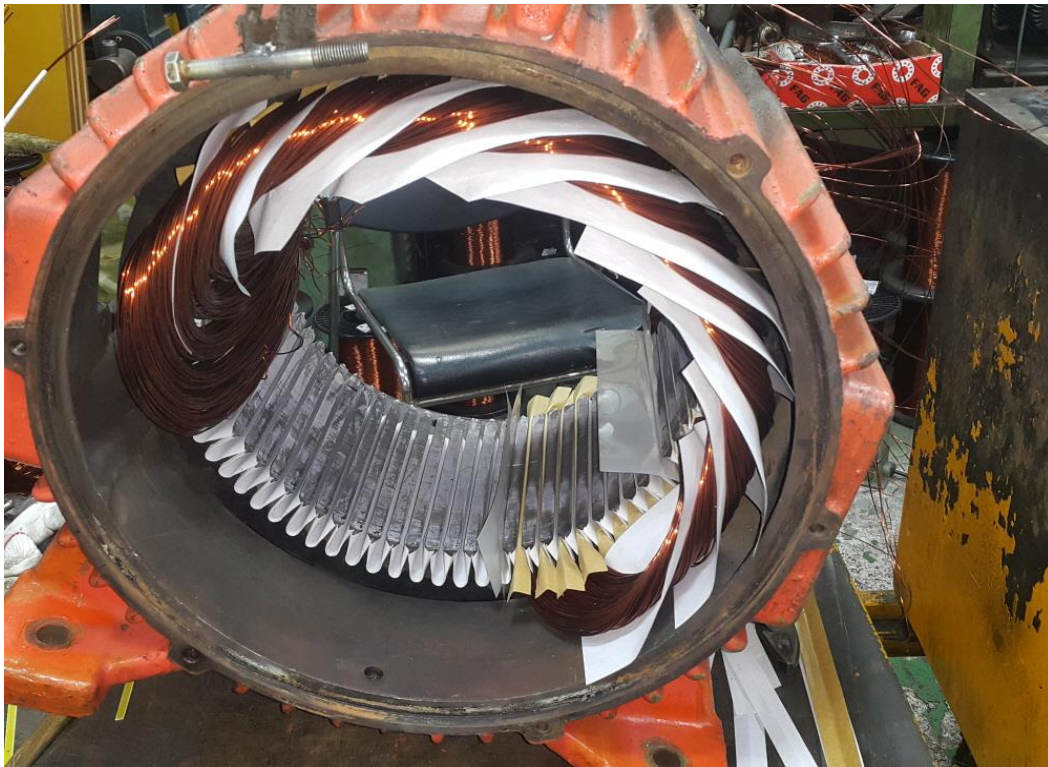

STATOR권체

재 권선실시

JIN YANG

# 작업 공정 사진

작업공정

권선형 MOTOR 100HP 6P REWINDING

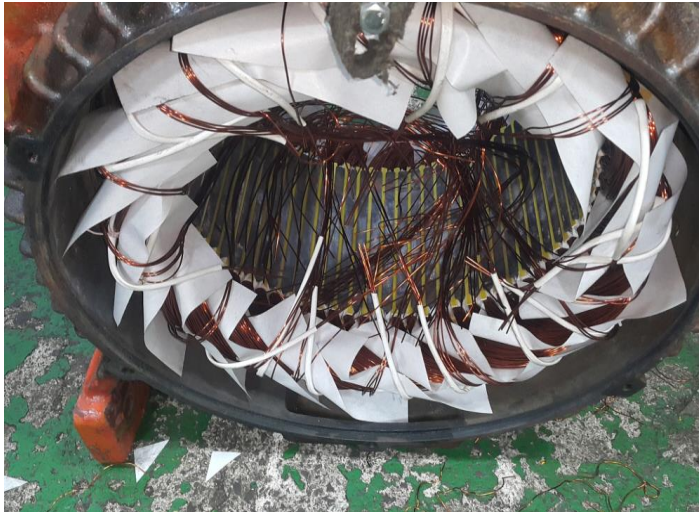

STATOR권체

재 권선실시

작업공정

권선형 MOTOR 100HP 6P REWINDING

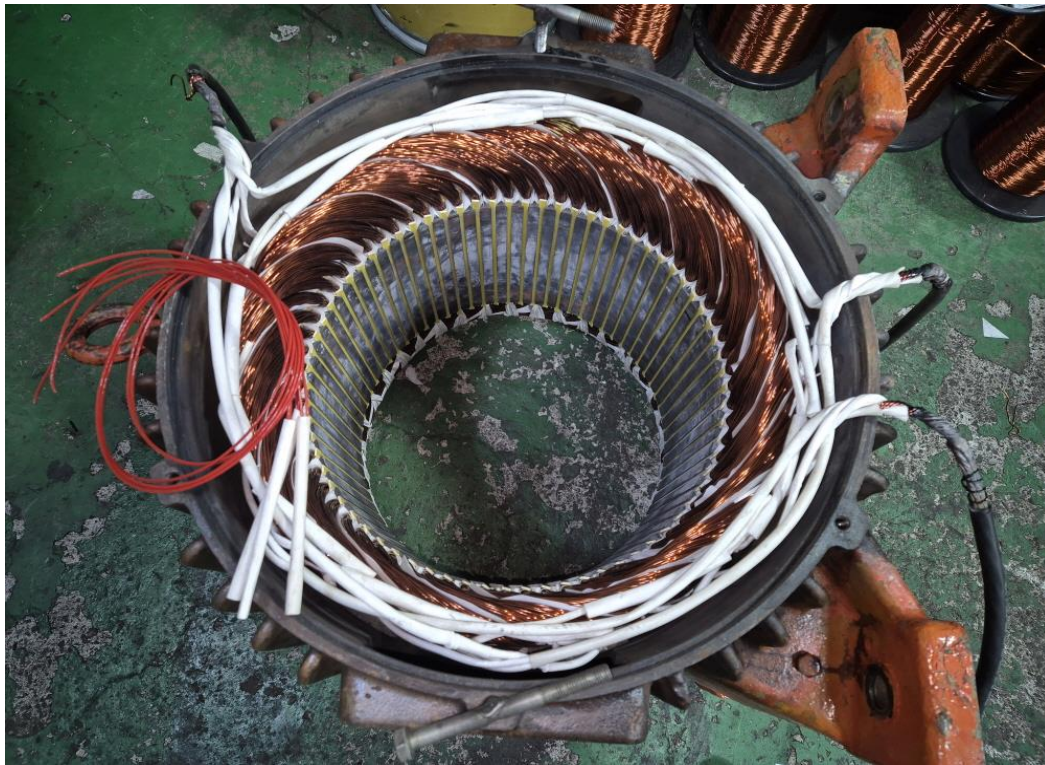

STATOR권체

재 권선 및 결선작업

JIN YANG

작업 공정 사진

작업공정

권선형 MOTOR 100HP 6P REWINDING



STATOR권체

INSULATING VARNISH DIPPING DRYING 실시 후

작업공정

권선형 MOTOR 100HP 6P REWINDING

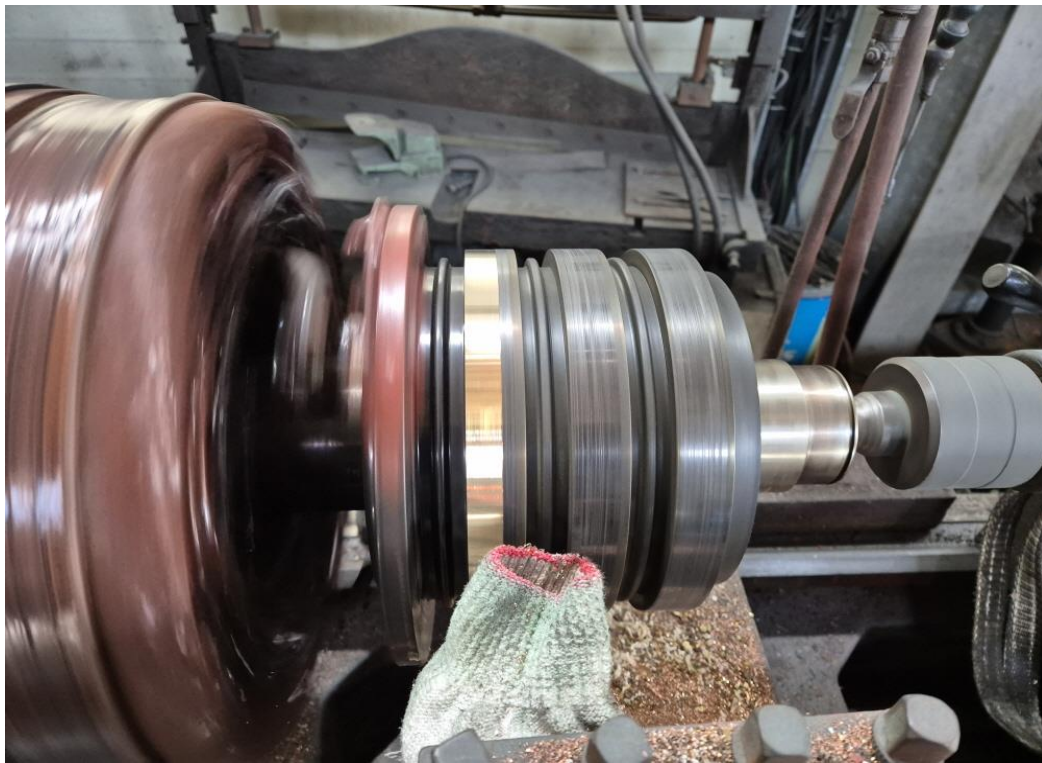

ROTOR

SLIP RING 동심도가공

JIN YANG

작업 공정 사진

작업공정

권선형 MOTOR 100HP 6P REWINDING



ROTOR

SLIP RING 동심도가공 후 URETHANE MODIFIED ACRYLIC COATING 실시

작업공정





권선형 MOTOR 100HP 6P REWINDING



ROTOR

BALANCING 실시

JIN YANG	작업 공정 사진
작업공정	권선형 MOTOR 100HP 6P REWINDING
	
ROTOR	교정된 UNBALANCE REPORT참조
작업공정	권선형 MOTOR 100HP 6P REWINDING
	
소모품	교환될 BRUSH 18EA & BEARING 3대분

JIN YANG	작업 공정 사진
작업공정	권선형 MOTOR 100HP 6P REWINDING
 <p data-bbox="137 813 225 846">부하측</p>	 <p data-bbox="1310 506 1398 539">반부하</p>
소모품	BEARING예열 실시
작업공정	권선형 MOTOR 100HP 6P REWINDING
	
ROTOR	BEARING 예열교환 및 GREASE CHARGING 조립실시

JIN YANG	작업 공정 사진
----------	----------

작업공정	권선형 MOTOR 100HP 6P REWINDING
------	------------------------------

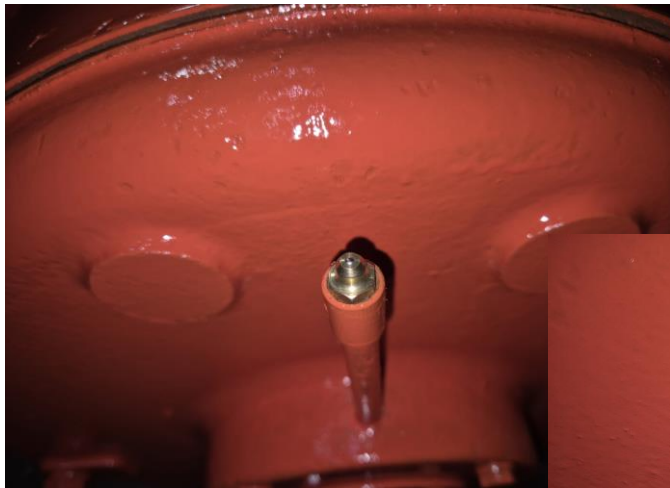

조립부품	GREASE CHARGING구 3대 모두 교환
------	---------------------------

GREASE CHARGING을 1500시간 주기마다 약 40g씩 꼭 하십시오

작업공정	권선형 MOTOR 100HP 6P REWINDING
------	------------------------------



소모품	BRUSH 6EA 전량 교환
-----	-----------------

JIN YANG

작업 공정 사진

작업공정

권선형 MOTOR 100HP 6P REWINDING



출고검사

STATOR 절연저항 & 각 상별 권선저항

작업공정

권선형 MOTOR 100HP 6P REWINDING



출고검사

ROTOR 절연저항 & 각 상별 권선저항

JIN YANG

작업 공정 사진

작업공정

권선형 MOTOR 100HP 6P REWINDING



1차



2차

출고검사

절연내력 시험

작업공정

권선형 MOTOR 100HP 6P REWINDING



출고검사

제습 HEATER 절연저항 & 권선저항 및 220V일때 CURRENT

JIN YANG

작업 공정 사진

작업공정

권선형 MOTOR 100HP 6P REWINDING

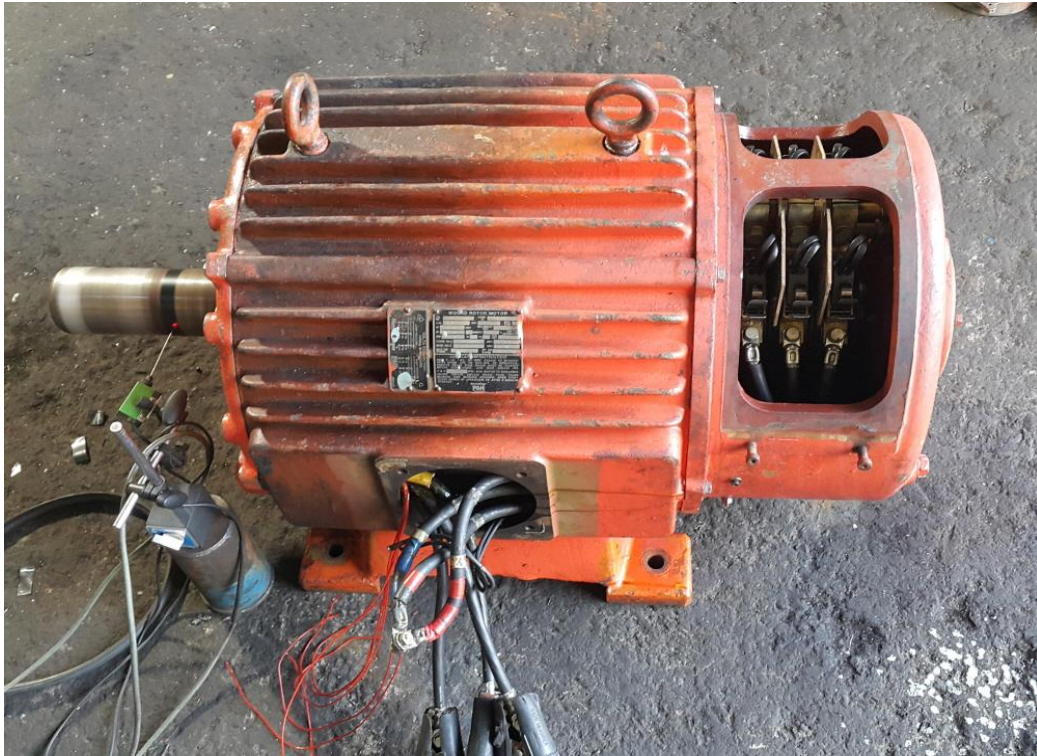

출고검사

시운전 TEST 실시

작업공정

권선형 MOTOR 100HP 6P REWINDING

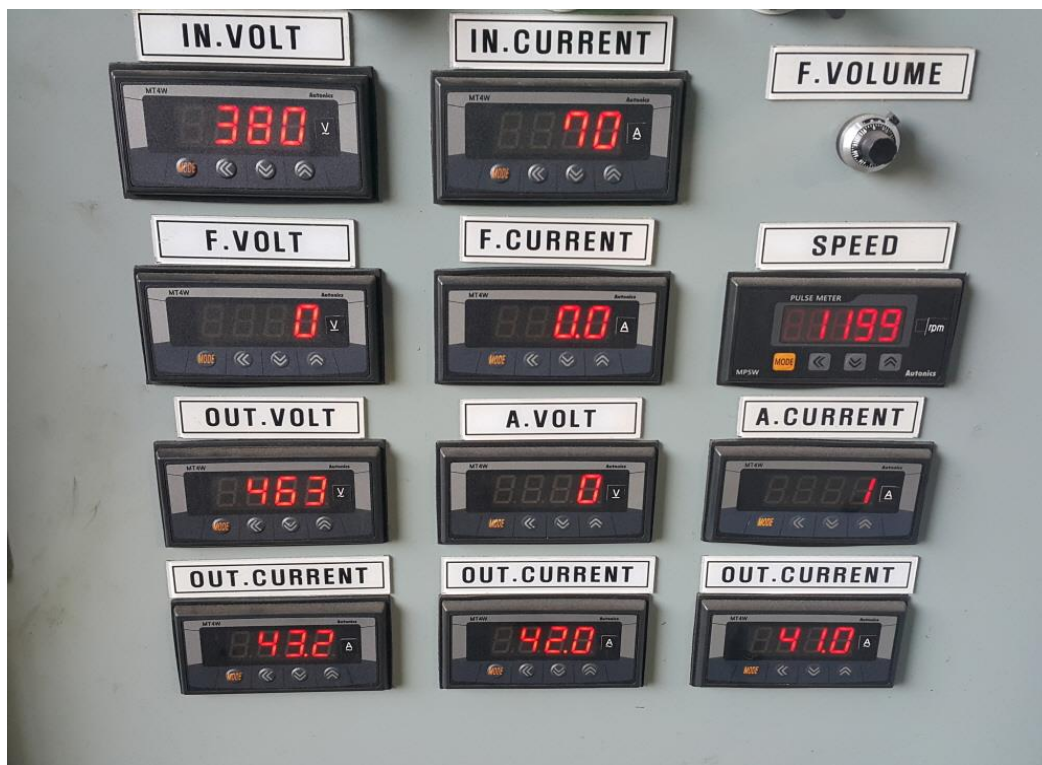

출고검사

시운전 TES 실시 운전 CURRENT

JIN YANG

# 작업 공정 사진

작업공정

권선형 MOTOR 100HP 6P REWINDING



출고검사

ROTOR 출력 전압

작업공정

권선형 MOTOR 100HP 6P REWINDING



반부하

부하



출고검사

진동검사

JIN YANG

작업 공정 사진

작업공정

권선형 MOTOR 100HP 6P REWINDING



출고검사

소음검사

작업공정

권선형 MOTOR 100HP 6P REWINDING



Ass'y

출고검사 후 및 COLOR PAINTING

# BALANCING INSPECTION REPORT

## SETUP

PART NAME : 권선형 ROTOR 3번			
CUSTOMER :			
TEST TIME : 2025. 2.23 9:36:30			
GRADE :	G 6.3	RATING SPEED :	1200 rpm
WEIGHT :	222.000 kg	TESTING SPEED :	503 rpm
DIAMETER :	350 mm	CORRECTION :	ADD
ACCEPTABLE UNBALANCE			
PLANE1 :	32.7 gr	PLANE2 :	32.7 gr

## INITIAL UNBALANCE

	PLANE1	PLANE2
UNBALANCE	30.4 gr	22.4 gr
ANGLE	352 deg	169 deg
RESULT	ACCEPT	ACCEPT

## CORRECT UNBALANCE

	PLANE1	PLANE2
UNBALANCE	8.3 gr	4.9 gr
ANGLE	327 deg	353 deg
RESULT	ACCEPT	ACCEPT

CORRECT UNBALANCE GRAPH (max = 10.0 gr )

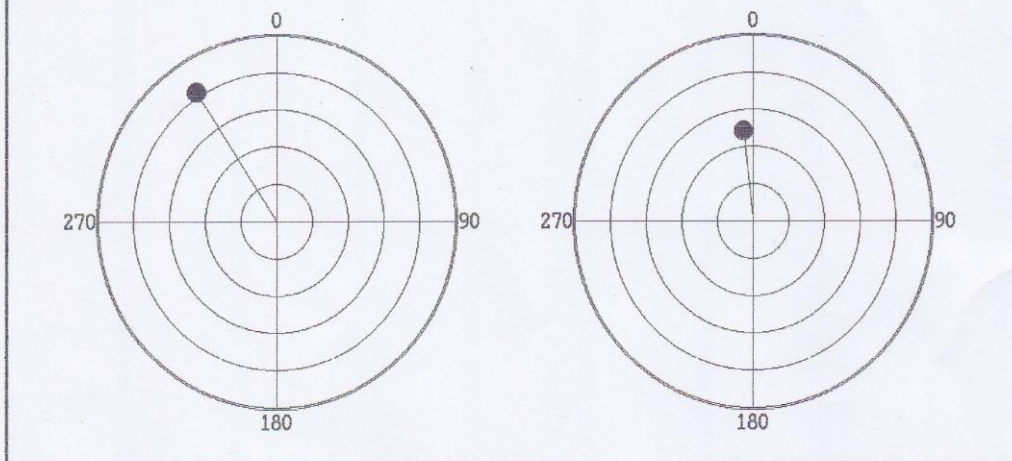

진 양 전 기  
 경남 마산시 내서읍 중리 1123-3번지  
 TEL (055) - 231-9318-9  
 FAX (055) - 231-9314



