

작업공정사진철

고객명: (주)
공사명: 제강공장 전기로 회수조 펌프 2호기

규격: 고압 MOTOR 3300V 250HP 6P

REPAIR 내역: 분해 및 불순물 CLEANSING DRYING
INSULATING VARNISH DIPPING DRYING
BALANCING 및 UNBALANCE교정
양측 HOUSING METALLIZING 연마
BEARING교환 조립
출고검사 시운전 TEST



<http://jinyangmotor.com/>



JIN YANG

작업 공정 사진

작업공정

AC MOTOR 250HP 6P 입고검사



Ass'y

분해 전

작업공정

AC MOTOR 250HP 6P 입고검사



권선검사

절연저항 & 각 상별 권선저항

JIN YANG

작업 공정 사진

작업공정

AC MOTOR 250HP 6P 입고검사

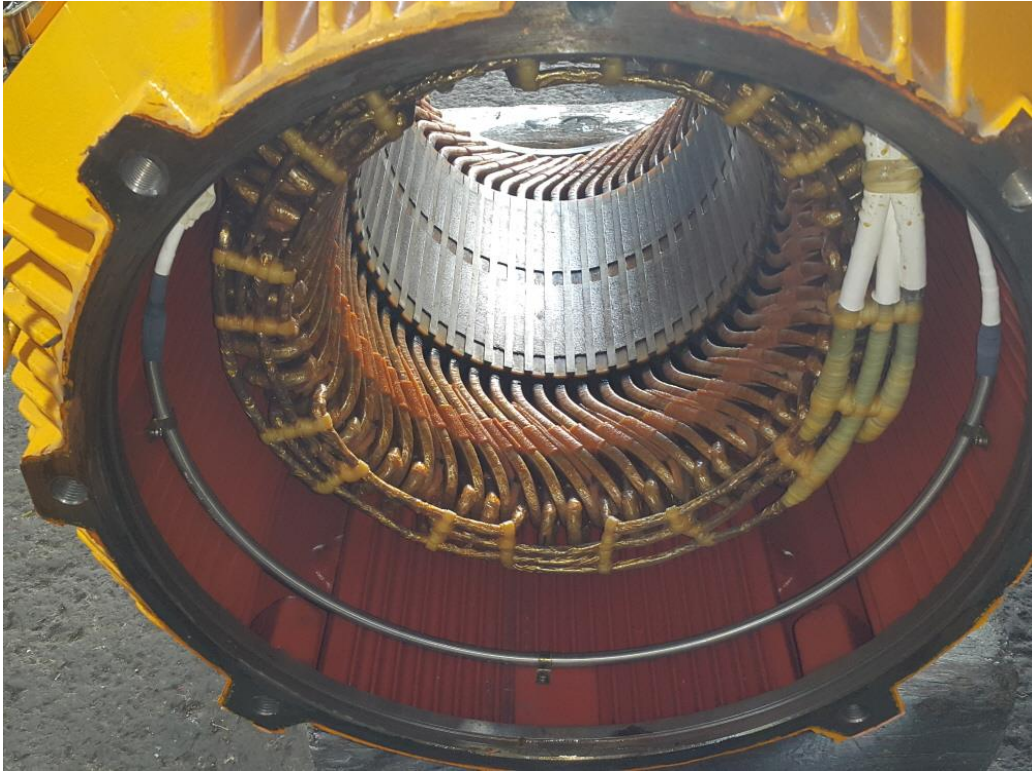

STATOR 권체

권선상태 양호

작업공정

AC MOTOR 250HP 6P 입고검사



ROTOR

분해 후 양호

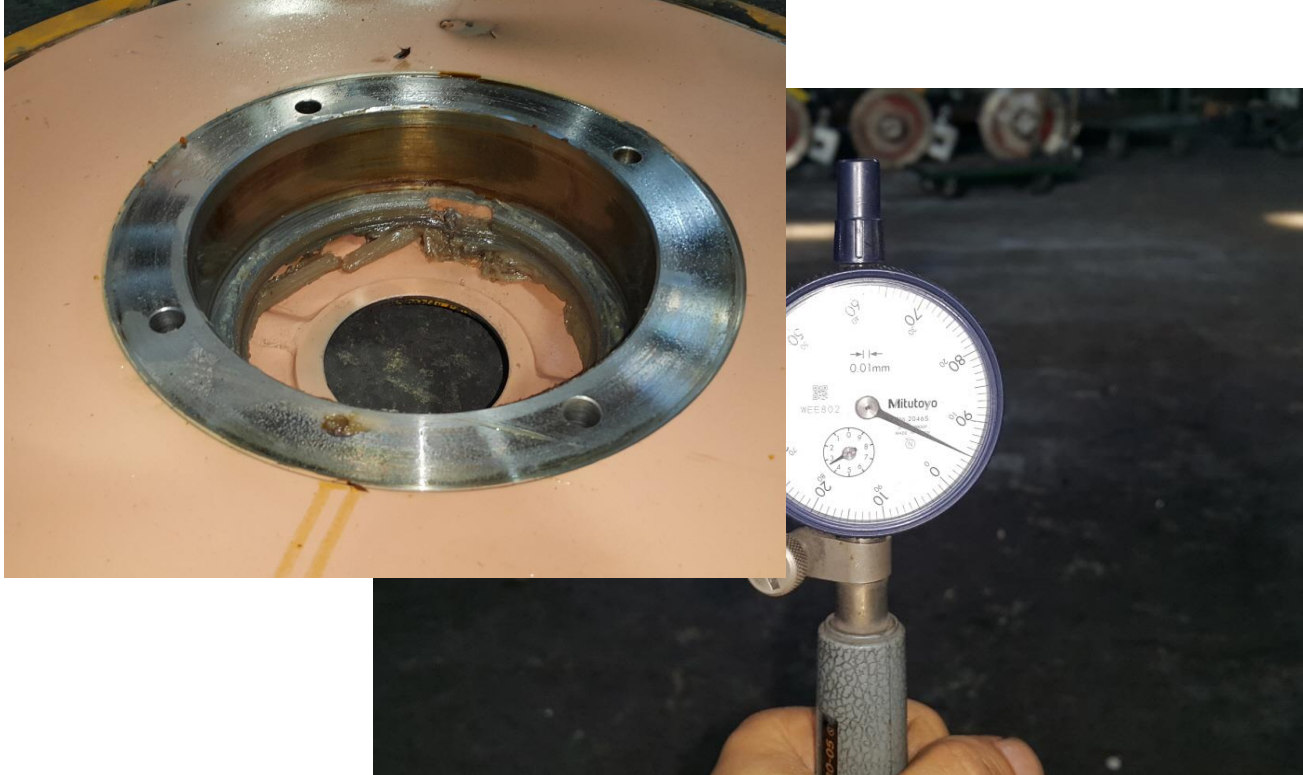
JIN YANG	작업 공정 사진
작업공정	AC MOTOR 250HP 6P 입고검사
	
BRACKET	부하측 HOUSING 측정치 5/100으로 불량
작업공정	AC MOTOR 250HP 6P 입고검사
	
BRACKET	반 부하측 HOUSING 측정치 5/100으로 불량

JIN YANG

작업 공정 사진

작업공정

AC MOTOR 250HP 6P OVERHAUL

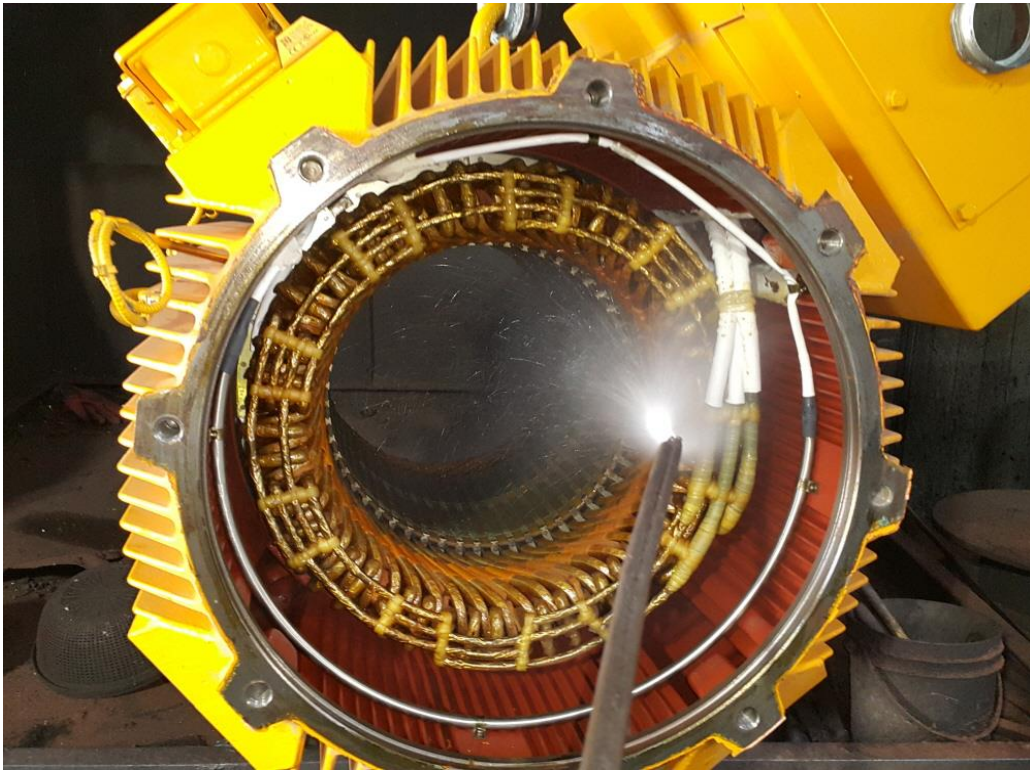

STATOR 권체

세척 실시

작업공정

AC MOTOR 250HP 6P OVERHAUL



STATOR 권체

세척 후 건조실시

JIN YANG

작업 공정 사진

작업공정

AC MOTOR 250HP 6P OVERHAUL



STATOR 권체

URETHANE MODIFIED ACRYLIC COATING 실시

작업공정

AC MOTOR 250HP 6P OVERHAUL



ROTOR

BALANCING 및 교정된 UNBALANCE REPOTR참조

JIN YANG

작업 공정 사진

작업공정

AC MOTOR 250HP 6P OVERHAUL



BRACKET

부하측 HOUSING 보수 후 검사 0/100

작업공정

AC MOTOR 250HP 6P OVERHAUL



BRACKET

반 부하측 HOUSING 보수 후 검사 0/100

JIN YANG

작업 공정 사진

작업공정

AC MOTOR 250HP 6P OVERHAUL

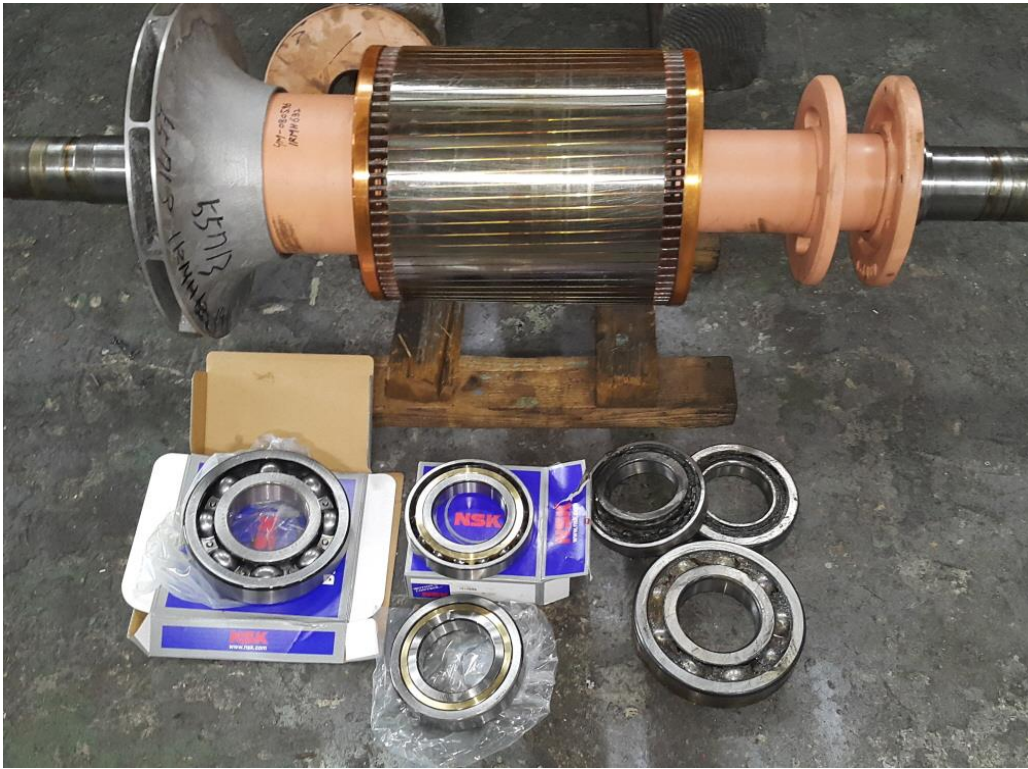

ROTOR

BEARING 교환 실시



작업공정

AC MOTOR 250HP 6P OVERHAUL

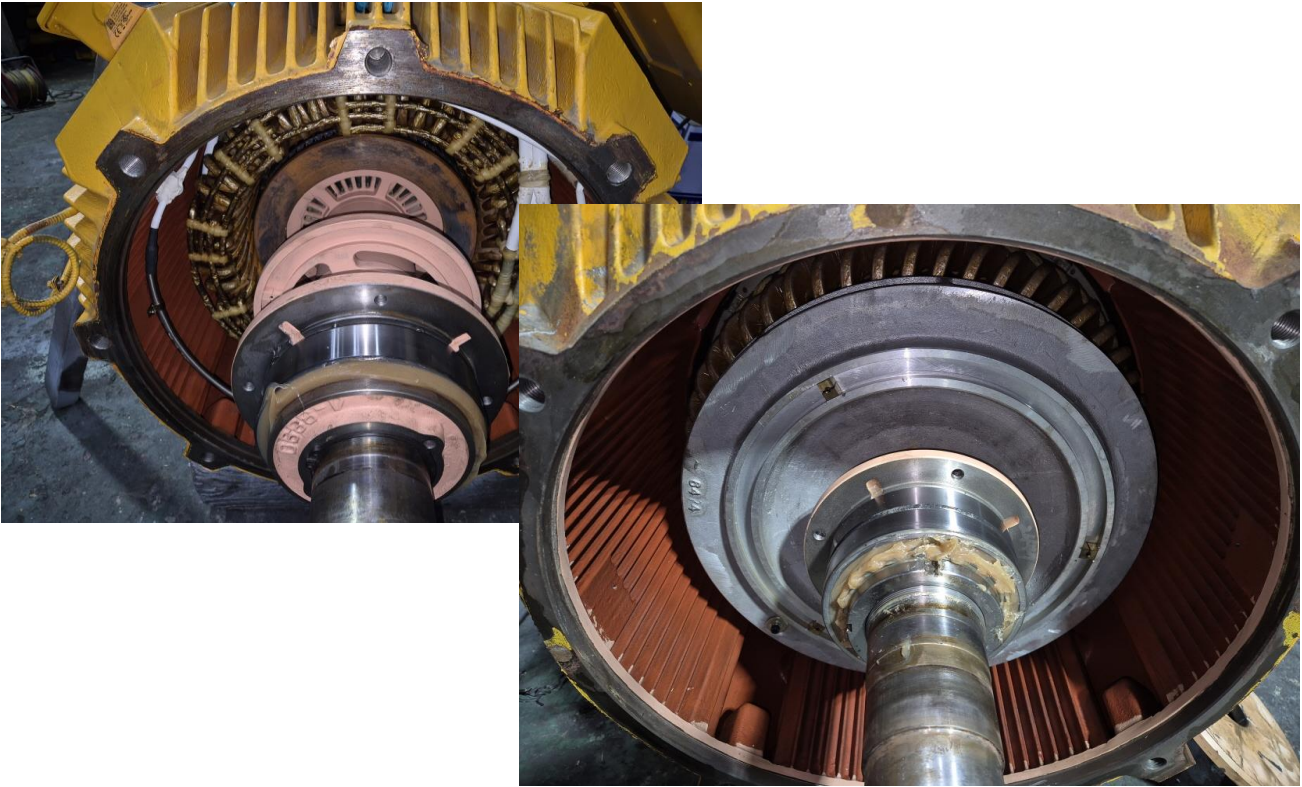

소모품

BEARING예열 교환

JIN YANG	작업 공정 사진
작업공정	AC MOTOR 250HP 6P OVERHAUL
	
조립부품	BEARING 예열교환 및 GREASE CHARGING 조립실시
작업공정	AC MOTOR 250HP 6P OVERHAUL
	
조립부품	세척 후 예열 및 조립실시

JIN YANG

작업 공정 사진

작업공정

AC MOTOR 250HP 6P OVERHAUL



출고검사

절연저항 & 각상별 권선저항

작업공정

AC MOTOR 250HP 6P OVERHAUL



출고검사

절연내력시험

JIN YANG

작업 공정 사진

작업공정

AC MOTOR 250HP 6P OVERHAUL



출고검사

시운전 TEST 실시

작업공정

AC MOTOR 250HP 6P OVERHAUL

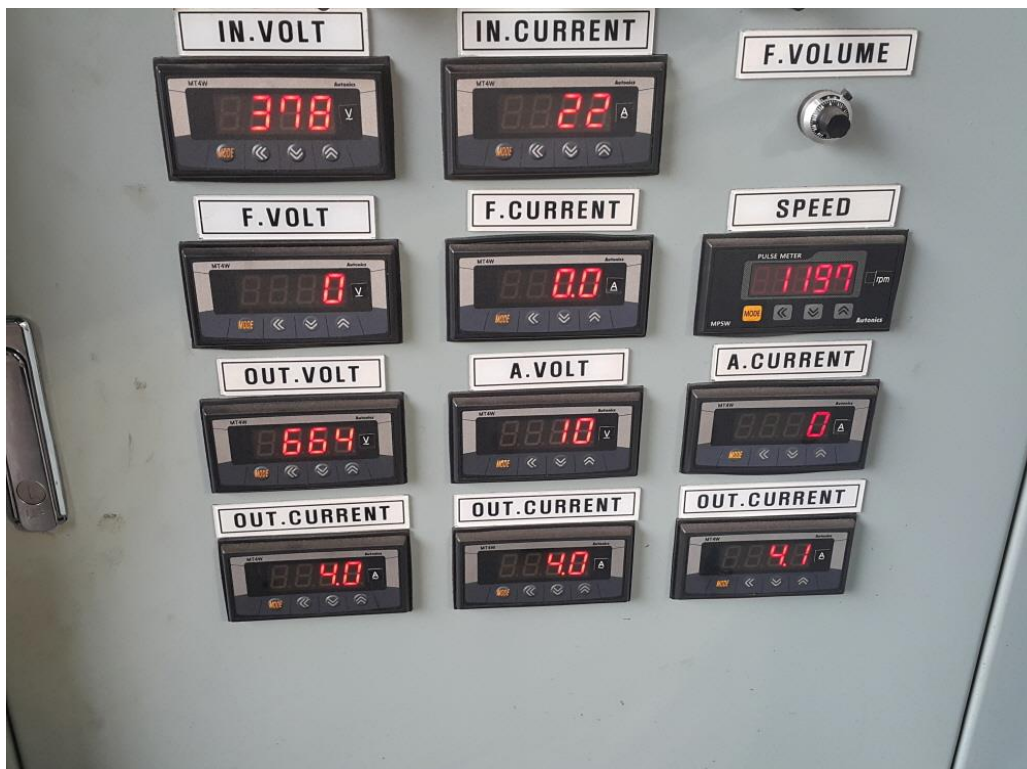

출고검사

RUNNING TEST 실시 656V 운전 CURRENT

JIN YANG

작업 공정 사진

작업공정

AC MOTOR 250HP 6P OVERHAUL

부하



반 부하



소음검사

출고검사

진동 & 소음검사

작업공정

AC MOTOR 250HP 6P OVERHAUL



Ass'y

출고검사 후

BALANCING INSPECTION REPORT

SETUP

PART NAME : AC ROTOR 6P			
CUSTOMER : [REDACTED]			
TEST TIME : 2024.10.14 12:30:13			
GRADE	: G 6.3	RATING SPEED	: 1200 rpm
WEIGHT	: 385.000 kg	TESTING SPEED	: 539 rpm
DIAMETER	: 350 mm	CORRECTION	: ADD
ACCEPTABLE UNBALANCE			
PLANE1	: 55.2 gr	PLANE2	: 55.2 gr

INITIAL UNBALANCE

	PLANE1	PLANE2
UNBALANCE	46.1 gr	22.5 gr
ANGLE	326 deg	201 deg
RESULT	ACCEPT	ACCEPT

CORRECT UNBALANCE

	PLANE1	PLANE2
UNBALANCE	14.6 gr	19.3 gr
ANGLE	328 deg	235 deg
RESULT	ACCEPT	ACCEPT

CORRECT UNBALANCE GRAPH (max = 50.0 gr)

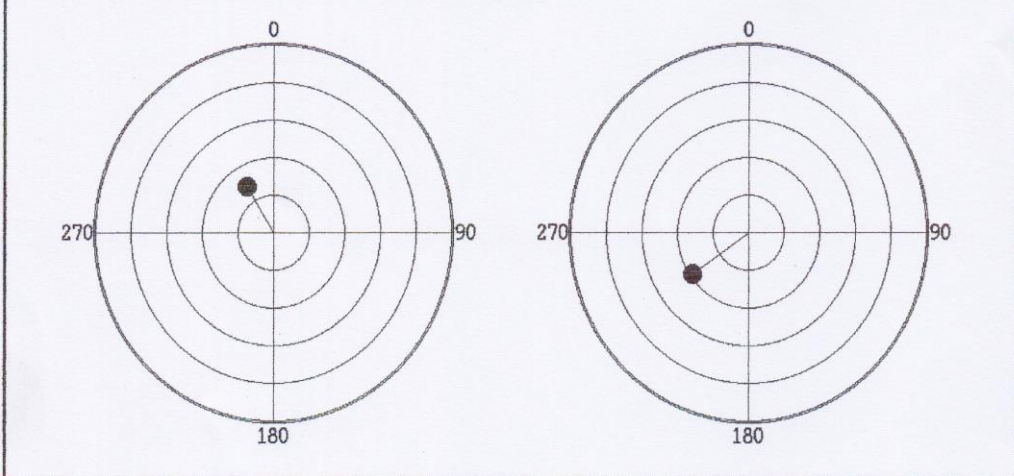

진양전기
 경남 마산시 내서읍 중리 1123-3번지
 TEL (055) - 231-9318-9
 FAX (055) - 231-9314