

## 출고검사 공정 사진철

고객명: 산업

공사명: SUBMERSIBLE PUMP MOTOR 예방정비

규격: PUMP MOTOR 380V 60HP 6P

REPAIR 내역: 분해 조립 및 조립부품 불순물 CLEANSING  
INSULATING VARNISH DIPPING DRYING  
BALANCING 및 UNBALANCE교정  
고압력 MECHANICAL SEAL교환  
OIL 및 BEARING 교환  
입 출고검사 시운전 TEST 및 COLOR PAINTING



<http://jinyangmotor.com/>



JIN YANG	작업 공정 사진
작업공정	수중 PUMP MOTOR 60HP 4P OVERHAUL
	
조립부품	녹 제거 GRINDING 실시
작업공정	수중 PUMP MOTOR 60HP 4P OVERHAUL
	
STATOR권체	세척 후 절연건조 실시

JIN YANG

작업 공정 사진

작업공정

수중 PUMP MOTOR 60HP 4P OVERHAUL

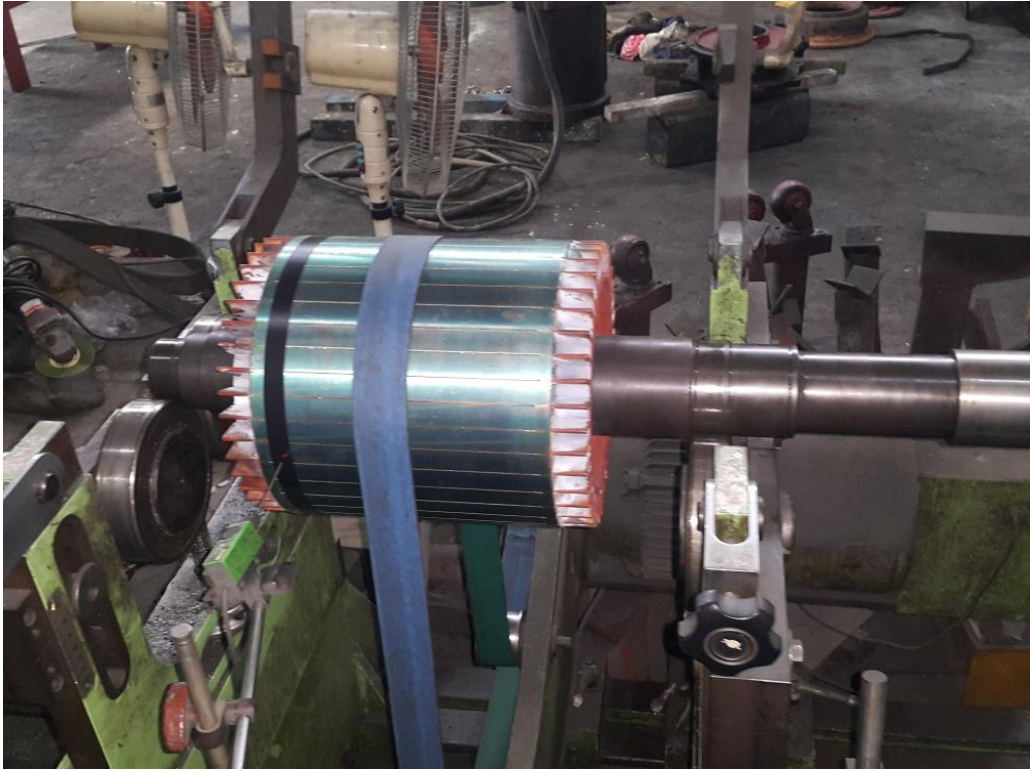

ROTOR

BALANCING실시 및 교정된 UNBALANCE REPORT참조

작업공정

수중 PUMP MOTOR 60HP 4P OVERHAUL



IMPELLER

BALANCING실시 및 교정된 UNBALANCE REPORT참조

JIN YANG

작업 공정 사진

작업공정

수중 PUMP MOTOR 60HP 4P OVERHAUL



IMPELLER

기존 UNBALANCE교정 전

작업공정

수중 PUMP MOTOR 60HP 4P OVERHAUL



IMPELLER

UNBALANCE교정 후

JIN YANG

작업 공정 사진

작업공정

수중 PUMP MOTOR 60HP 4P OVERHAUL



조립부품

MECHANICAL SEAL 및 ADAPTER의 부품

작업공정

수중 PUMP MOTOR 60HP 4P OVERHAUL

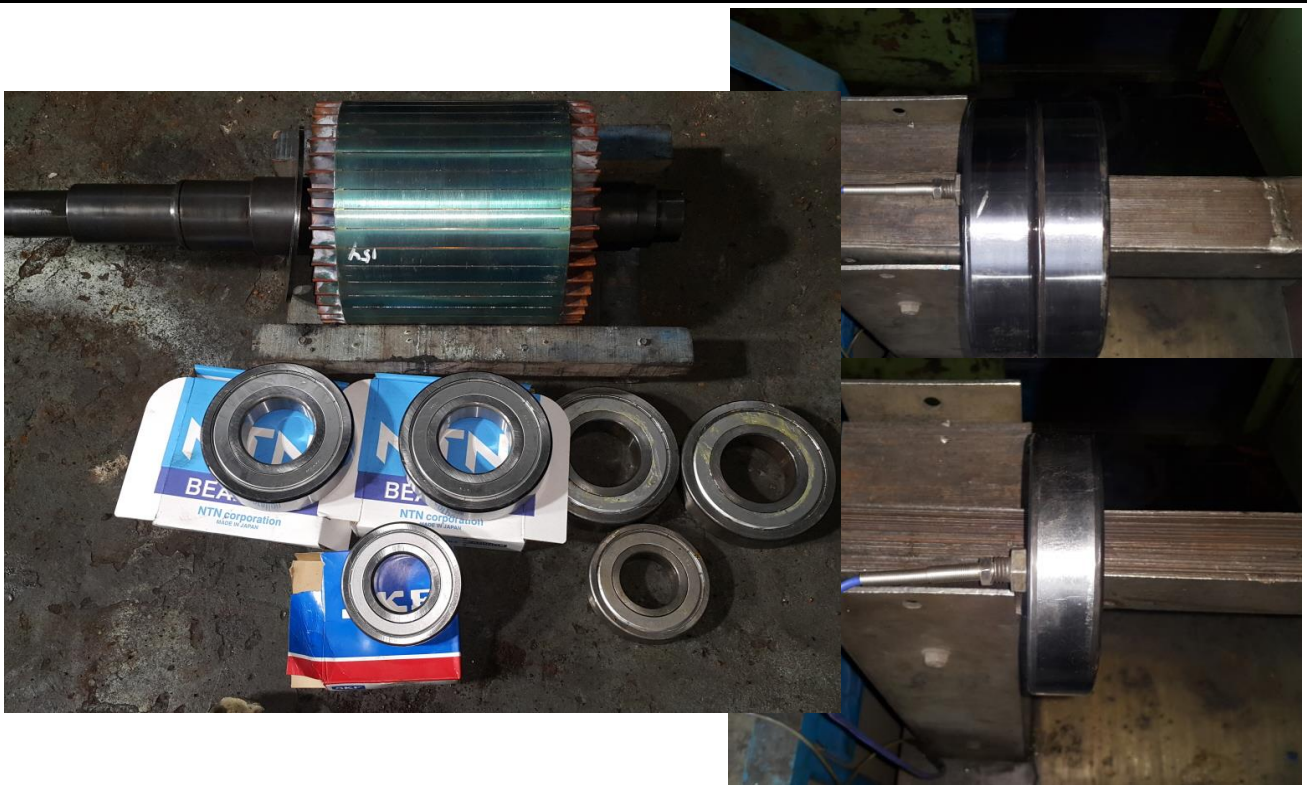

ROTOR

BEARING 예열교환 실시

JIN YANG

작업 공정 사진

작업공정

수중 PUMP MOTOR 60HP 4P OVERHAUL

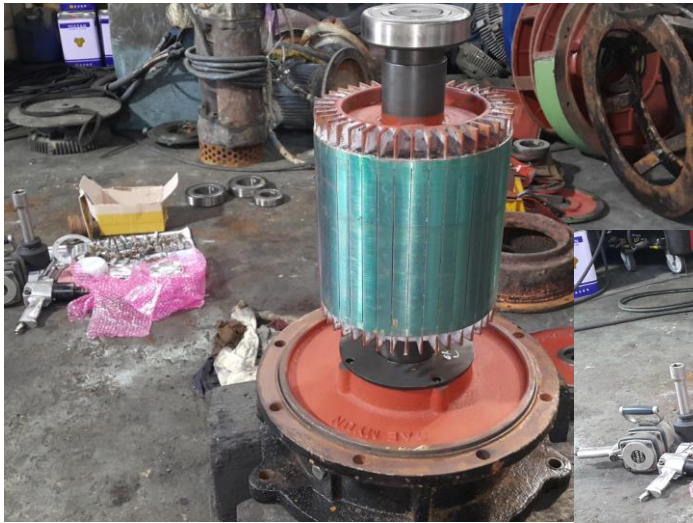

조립

OIL CHAMBER 및 Ass'y 조립실시



작업공정

수중 PUMP MOTOR 60HP 4P OVERHAUL



소모 부품

고압력 MECHANICAL SEAL 조립실시

JIN YANG	작업 공정 사진
작업공정	수중 PUMP MOTOR 60HP 4P OVERHAUL
	
소모 품	MECHANICAL SEAL & OIL CHARGING 조립실시
작업공정	수중 PUMP MOTOR 60HP 4P OVERHAUL
	
조립	WATER CHAMBER 조립실시

JIN YANG

# 작업 공정 사진

작업공정

수중 PUMP MOTOR 60HP 4P OVERHAUL



IMPELLER고정 ADAPTER



Ass'y

권체 조립 실시

작업공정

수중 PUMP MOTOR 60HP 4P OVERHAUL



출고검사

절연저항 & 각 상 LINE별 권선저항

JIN YANG

작업 공정 사진

작업공정

수중 PUMP MOTOR 60HP 4P OVERHAUL



출고검사

절연내력 시험





작업공정

수중 PUMP MOTOR 60HP 4P OVERHAUL



출고검사

시운전 TEST 실시

JIN YANG	작업 공정 사진
작업공정	수중 PUMP MOTOR 60HP 4P OVERHAUL
	
출고검사	시운전 TEST △운전 CURRENT
작업공정	수중 PUMP MOTOR 60HP 4P OVERHAUL
<p data-bbox="156 1285 252 1368">부하측 상면</p>  	<p data-bbox="1337 1285 1433 1368">부하측 좌 우</p>  <p data-bbox="1337 1682 1449 1765">반부하측 좌 우</p> 
출고검사	진동검사

JIN YANG

작업 공정 사진

작업공정

수중 PUMP MOTOR 60HP 4P OVERHAUL



출고검사

소음검사

작업공정



수중 PUMP MOTOR 60HP 4P OVERHAUL



CONTROL LINE

흑색: 물 유입감지, 적색: MOTOR 과열 감지 PT-100Ω

백색: BEARING 과열 감지 PT-100Ω

JIN YANG	작업 공정 사진
작업공정	수중 PUMP MOTOR 60HP 4P OVERHAUL
	
CONTROL LINE	CONTROL LINE FLEXIBLE 단말처리 했슴
작업공정	수중 PUMP MOTOR 60HP 4P OVERHAUL
	
출고검사 후	COLOR PAINTING

ROTOR

## BALANCING INSPECTION REPORT

### SETUP

PART NAME : AC ROTOR 6P			
CUSTOMER : 산업			
TEST TIME : 2023. 5.26 15:30:18			
GRADE	: G 6.3	RATING SPEED	: 1200 rpm
WEIGHT	: 154.000 kg	TESTING SPEED	: 551 rpm
DIAMETER	: 250 mm	CORRECTION	: ADD
ACCEPTABLE UNBALANCE			
PLANE1	: 30.9 gr	PLANE2	: 30.9 gr

### INITIAL UNBALANCE

	PLANE1	PLANE2
UNBALANCE	12.3 gr	6.5 gr
ANGLE	154 deg	347 deg
RESULT	ACCEPT	ACCEPT

### CORRECT UNBALANCE

	PLANE1	PLANE2
UNBALANCE	12.3 gr	6.5 gr
ANGLE	154 deg	347 deg
RESULT	ACCEPT	ACCEPT

CORRECT UNBALANCE GRAPH (max = 50.0 gr )

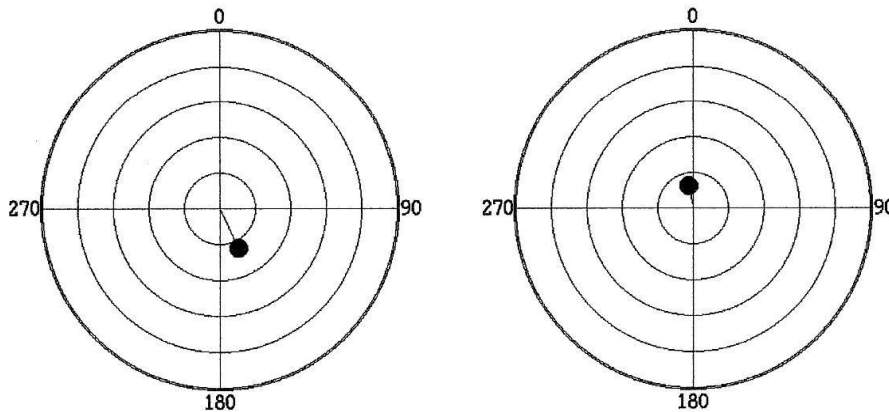

진양전기  
경남 마산시 내서읍 중리 1123-3번지  
TEL (055) - 231-9318-9  
FAX (055) - 231-9314

Jinwon Balancing Machine

Jinwon Engineering (053) 354-7387

IMPELLER

## BALANCING INSPECTION REPORT

SETUP

PROJECT NO: PUMP IMPELLER	
CUSTOMER :	
NO :	
TYPE :	
OPERATOR :	
PART NAME : IMPELLER	TEST TIME : 2023.05.30 20:17:34
GRADE : G6.3	RATING SPEED : 0 rpm
WEIGHT : 0.000 kg	TESTING SPEED : 610 rpm
RADIUS : 125 mm 125 mm	CORRECTION : REMOVE
ACCEPTABLE UNBALANCE(Unit:g)	
PLANE1 : 5.000	PLANE2 : 5.000

INITIAL UNBALANCE

	PLANE1	PLANE2
UNBALANCE	449.150 g	425.090 g
ANGLE	332 deg	150 deg
RESULT	NG	NG

CORRECT UNBALANCE

	PLANE1	PLANE2
UNBALANCE	3.170 g	3.310 g
ANGLE	29 deg	147 deg
RESULT	OK	OK

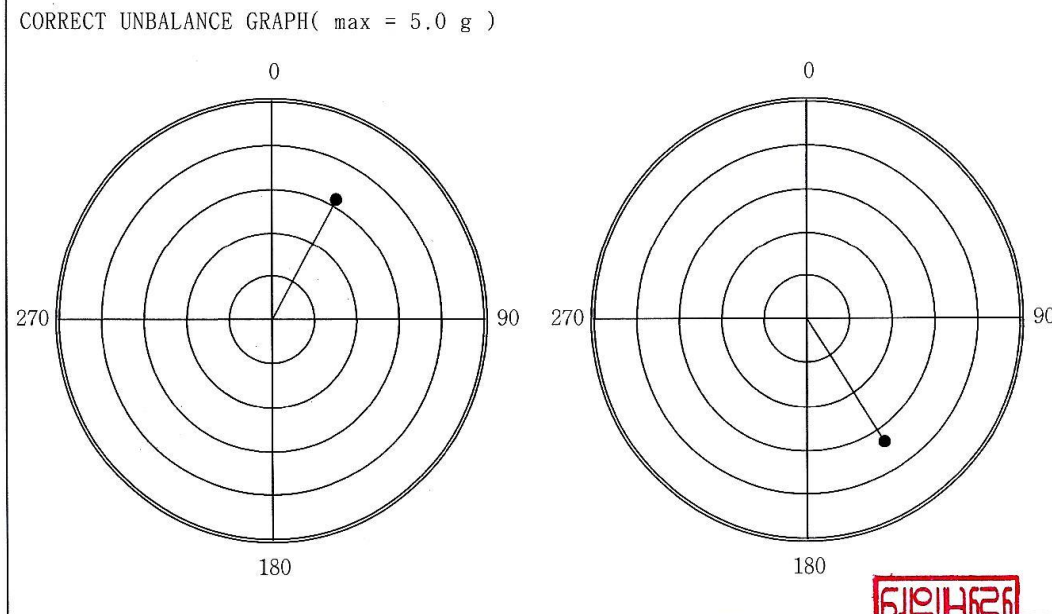

세원바  
 부산광역시 사상구 낙동대로905번길25  
 TEL)051-3271-1780 / FAX)051-3271-1782  
 E-mail : sw1780@hanmail.net

