

# 작업공정사진철

고객명:

공사명: INDUCTION MOTOR 예방정비



규격: AC MOTOR 440V 220KW 4P 2669RPM

REPAIR 내역: 분해 조립 및 조립부품 불순물 CLEANSING  
INSULATING VARNISH DIPPING DRYING  
BALANCING 및 UNBALANCE교정  
양측 HOUSING METALLIZING 연마  
MOTOR & BLOWER BEARING 교환  
입 출고검사 시운전 TEST 및 COLOR PAINTING



<http://jinyangmotor.com/>



|   |  |
|---|--|
| JIN YANG  | 작업 공정 사진   |
| 작업공정  | AC MOTOR 300HP 4P RECONDITION  |
|    |   |
| BRACKET   | 반 부하측 HOUSING 보수 후 검사  |
| 작업공정  | AC MOTOR 300HP 4P RECONDITION  |
|  |  |
| 소모품   | 교환될 BEARING 및 SUS BOLT류  |

JIN YANG

# 작업 공정 사진

작업공정

AC MOTOR 300HP 4P RECONDITION

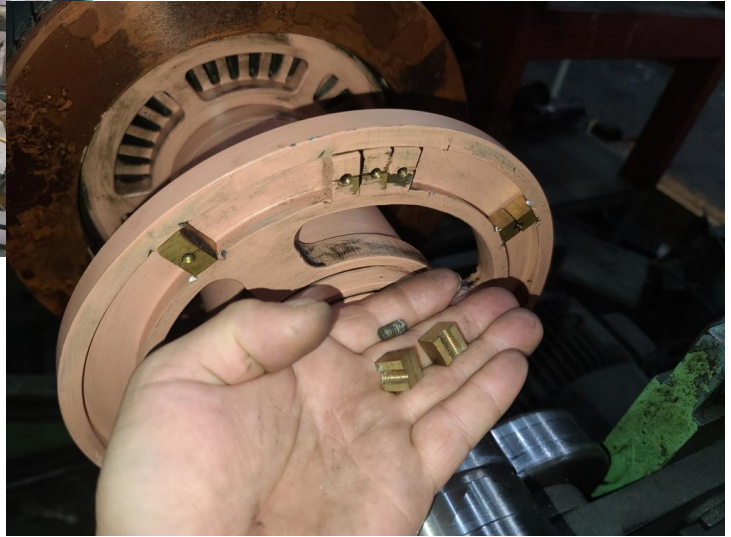
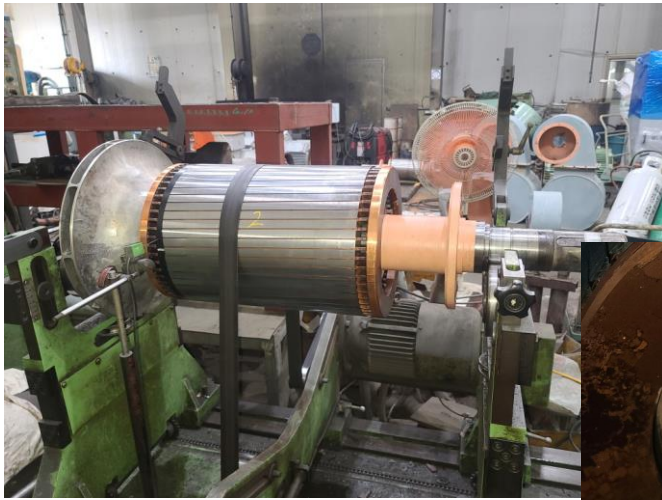

ROTOR 2호

BALANCING실시 및 UNBALANCE교정

작업공정

AC MOTOR 300HP 4P RECONDITION



교정 전

교정 후



2호

BALANCING실시 MONITORING 교정된 UNBALANCE REPORT참조  
1,3호는 UNBALANCE량이 기준치 이내입니다

JIN YANG

작업 공정 사진

작업공정

AC MOTOR 300HP 4P RECONDITION



BRACKET 1호

부하측 HOUSING METALLIZING 연마 후 검사 0/100

작업공정

AC MOTOR 300HP 4P RECONDITION



BRACKET 1호

반 부하측 HOUSING METALLIZING 연마 후 검사 0/100

JIN YANG

작업 공정 사진

작업공정

AC MOTOR 300HP 4P RECONDITION



BRACKET 2호

부하측 HOUSING METALLIZING 연마 후 검사 0/100

작업공정

AC MOTOR 300HP 4P RECONDITION



BRACKET 3호

부하측 HOUSING METALLIZING 연마 후 검사 0/100

JIN YANG

작업 공정 사진

작업공정

AC MOTOR 300HP 4P RECONDITION



소모 품

GREASE CHARGING BEARING 예열 삽입 실시

작업공정

AC MOTOR 300HP 4P RECONDITION





Ass'y

조립실시

GREASE CHARGING을 1200시간 주기마다 약60g씩 꼭 하십시오

<http://jinyangmotor.com/>

|  |                               |
|--|-------------------------------|
| JIN YANG   | 작업 공정 사진                      |
| 작업공정   | AC MOTOR 300HP 4P RECONDITION |
|   |                               |
| 조립부품   | SUS BOLT류 교환                  |
| 작업공정   | AC MOTOR 300HP 4P RECONDITION |
|  |                               |
| BLOWER   | BEARING교환 실시                  |

JIN YANG

# 작업 공정 사진

작업공정

AC MOTOR 300HP 4P RECONDITION



BLOWER

각 상별 권선저항 동일

작업공정

AC MOTOR 300HP 4P RECONDITION



1호

2호

3호

BLOWER

시운전 TEST 실시 운전 CURRENT

JIN YANG

작업 공정 사진

작업공정

AC MOTOR 300HP 4P RECONDITION



1호



2호



3호

출고검사

절연저항 & 각 상별 권선저항 동일

작업공정

AC MOTOR 300HP 4P RECONDITION



출고검사

시운전 TEST 실시

JIN YANG

작업 공정 사진

작업공정

AC MOTOR 300HP 4P RECONDITION



출고검사

시운전 TEST 운전 CURRENT

작업공정

AC MOTOR 300HP 4P RECONDITION



Ass'y

출고검사 후 COLOR PAINTING

1호

# BALANCING INSPECTION REPORT

## SETUP

|                                |              |               |            |
|--------------------------------|--------------|---------------|------------|
| PART NAME : AC ROTOR 220KW 1호  |              |               |            |
| CUSTOMER : 고려                  |              |               |            |
| TEST TIME : 2022. 8. 9 7:31:41 |              |               |            |
| GRADE                          | : G 6.3      | RATING SPEED  | : 2669 rpm |
| WEIGHT                         | : 400.000 kg | TESTING SPEED | : 553 rpm  |
| DIAMETER                       | : 550 mm     | CORRECTION    | : ADD      |
| ACCEPTABLE UNBALANCE           |              |               |            |
| PLANE1                         | : 25.8 gr    | PLANE2        | : 25.8 gr  |

## INITIAL UNBALANCE

|           | PLANE1  | PLANE2  |
|-----------|---------|---------|
| UNBALANCE | 9.6 gr  | 18.1 gr |
| ANGLE     | 285 deg | 256 deg |
| RESULT    | ACCEPT  | ACCEPT  |

## CORRECT UNBALANCE

|           | PLANE1  | PLANE2  |
|-----------|---------|---------|
| UNBALANCE | 9.6 gr  | 18.1 gr |
| ANGLE     | 285 deg | 256 deg |
| RESULT    | ACCEPT  | ACCEPT  |

CORRECT UNBALANCE GRAPH (max = 50.0 gr )

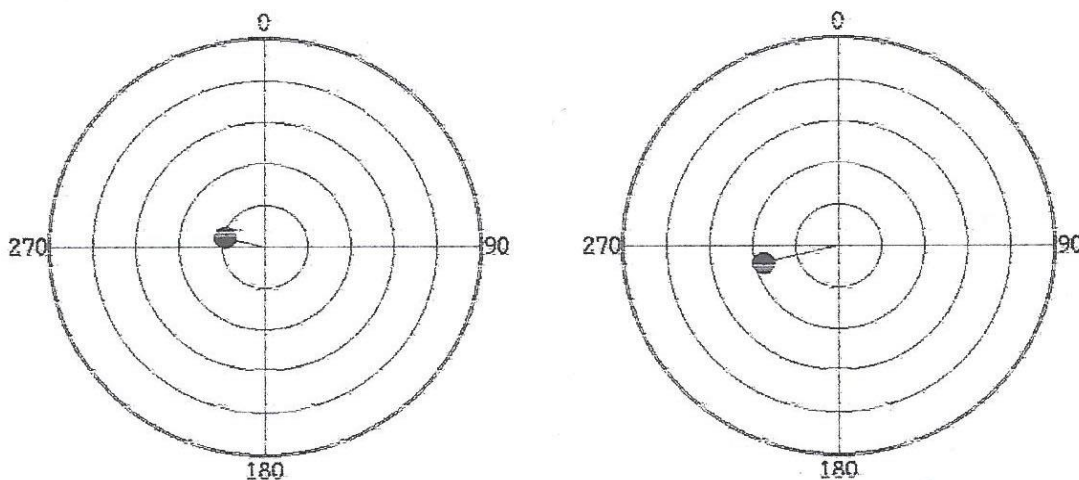

진양전기  
경남 마산시 내서읍 중리 1123-3번지  
TEL (055) - 231-9318-9  
FAX (055) - 231-9314

2호

# BALANCING INSPECTION REPORT

## SETUP

|                                |              |               |            |
|--------------------------------|--------------|---------------|------------|
| PART NAME : AC ROTOR 220KW 2호  |              |               |            |
| CUSTOMER : 고려                  |              |               |            |
| TEST TIME : 2022. 8. 9 7:55:44 |              |               |            |
| GRADE                          | : G 6.3      | RATING SPEED  | : 2669 rpm |
| WEIGHT                         | : 400.000 kg | TESTING SPEED | : 554 rpm  |
| DIAMETER                       | : 550 mm     | CORRECTION    | : ADD      |
| ACCEPTABLE UNBALANCE           |              |               |            |
| PLANE1                         | : 25.8 gr    | PLANE2        | : 25.8 gr  |

## INITIAL UNBALANCE

|           | PLANE1  | PLANE2  |
|-----------|---------|---------|
| UNBALANCE | 9.3 gr  | 13.2 gr |
| ANGLE     | 316 deg | 320 deg |
| RESULT    | ACCEPT  | ACCEPT  |

## CORRECT UNBALANCE

|           | PLANE1  | PLANE2  |
|-----------|---------|---------|
| UNBALANCE | 9.3 gr  | 13.2 gr |
| ANGLE     | 316 deg | 320 deg |
| RESULT    | ACCEPT  | ACCEPT  |

CORRECT UNBALANCE GRAPH (max = 50.0 gr )

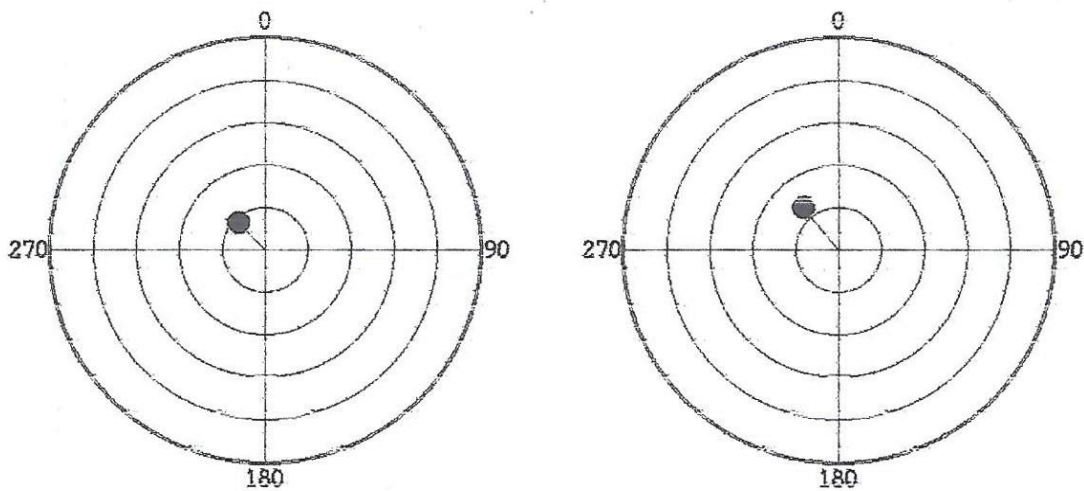

진 향 전 기  
 경남 마산시 내서읍 중리 1123-3번지  
 TEL (055) - 231-9318-9  
 FAX (055) - 231-9314

# BALANCING INSPECTION REPORT

## SETUP

|                                |              |               |            |
|--------------------------------|--------------|---------------|------------|
| PART NAME : AC ROTOR 220KW 3호  |              |               |            |
| CUSTOMER : 고려                  |              |               |            |
| TEST TIME : 2022. 8. 9 8:13:56 |              |               |            |
| GRADE                          | : G 6.3      | RATING SPEED  | : 2669 rpm |
| WEIGHT                         | : 400.000 kg | TESTING SPEED | : 554 rpm  |
| DIAMETER                       | : 550 mm     | CORRECTION    | : ADD      |
| ACCEPTABLE UNBALANCE           |              |               |            |
| PLANE1                         | : 25.8 gr    | PLANE2        | : 25.8 gr  |

## INITIAL UNBALANCE

|           | PLANE1  | PLANE2  |
|-----------|---------|---------|
| UNBALANCE | 8.1 gr  | 17.2 gr |
| ANGLE     | 155 deg | 168 deg |
| RESULT    | ACCEPT  | ACCEPT  |

## CORRECT UNBALANCE

|           | PLANE1  | PLANE2  |
|-----------|---------|---------|
| UNBALANCE | 8.1 gr  | 17.2 gr |
| ANGLE     | 155 deg | 168 deg |
| RESULT    | ACCEPT  | ACCEPT  |

CORRECT UNBALANCE GRAPH (max = 50.0 gr )

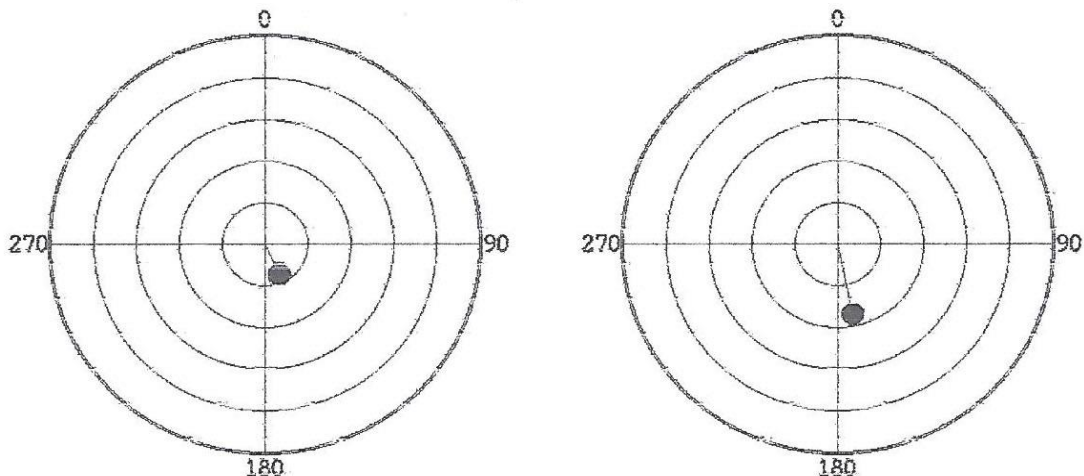

진양전기

경남 마산시 내서읍 중리 1123-3번지

TEL (055) - 231-9318-9

FAX (055) - 231-9314