

작업공정사진철

고객명:

공사명: AC MOTOR REWINDING

규격: AC MOTOR 110KW 2P 380V

REPAIR 내역: 분해 조립 및 조립부품 불순물 CLEANSING
INSULATING VARNISH DIPPING DRYING
COIL REWINDING
양측 SHAFT METALLIZING 연마
반 부하측 HOUSING METALLIZING 연마
BALANCING 및 UNBALANCE교정
BEARING 및 불량부품 교환
칩 출고검사 후 시운전TEST



<http://jinyangmotor.com/>



JIN YANG

작업 공정 사진

작업공정

AC MOTOR 110KW 2P 입고검사



조립부품

스팀세척 실시

작업공정

AC MOTOR 110KW 2P 입고검사



STATOR권체

스팀세척 실시

JIN YANG

작업 공정 사진

작업공정

AC MOTOR 110KW 2P 입고검사

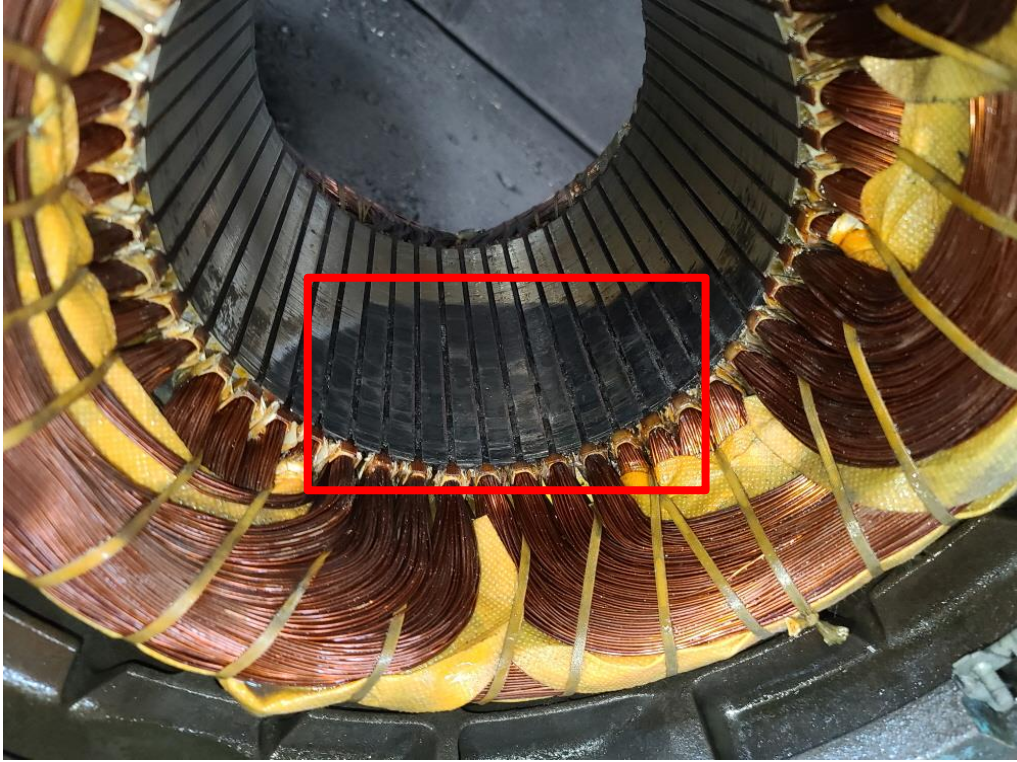

STATOR권체

스팀세척 후 ROTOR와의 회전 마찰 발열로 인하여 INSULATOR에 상당한 문제가 있을것으로 짐작하고 건조 실시 후 재검사 실시

작업공정

AC MOTOR 110KW 2P 입고검사



STATOR권체

세척건조 후 절연검사 불량으로 재 권선 필요로 판단 했슴

JIN YANG

작업 공정 사진

작업공정

AC MOTOR 110KW 2P REWINDING

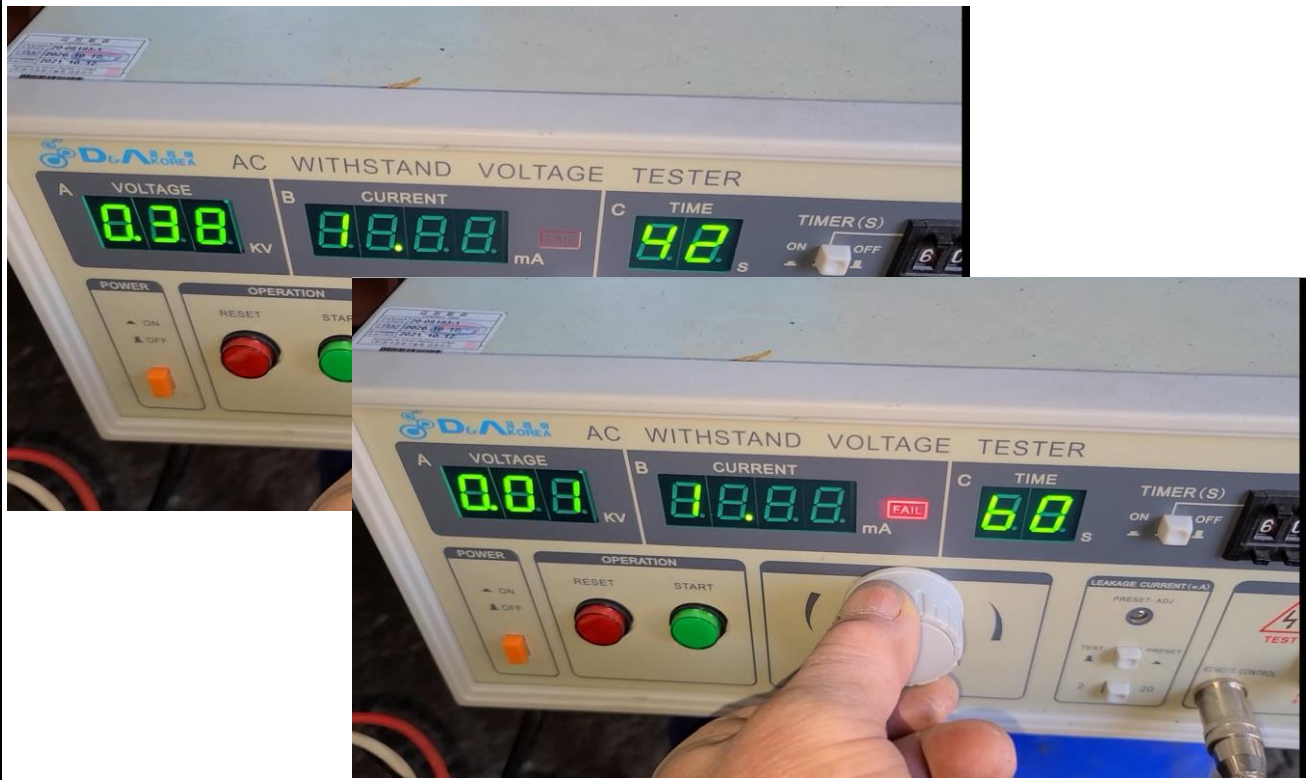

절연내력시험

360~380V상승시 지락 차단됨

작업공정

AC MOTOR 110KW 2P REWINDING

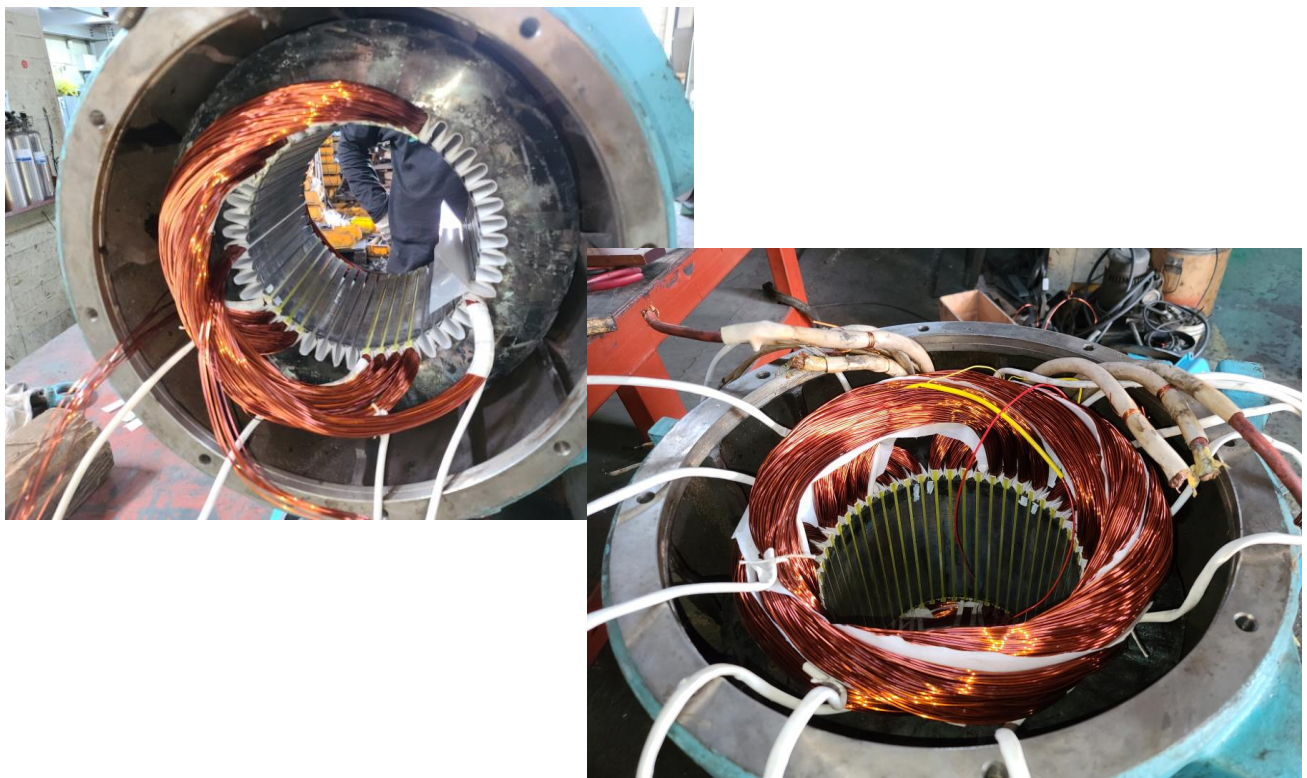





STATOR권체

재 권선 실시

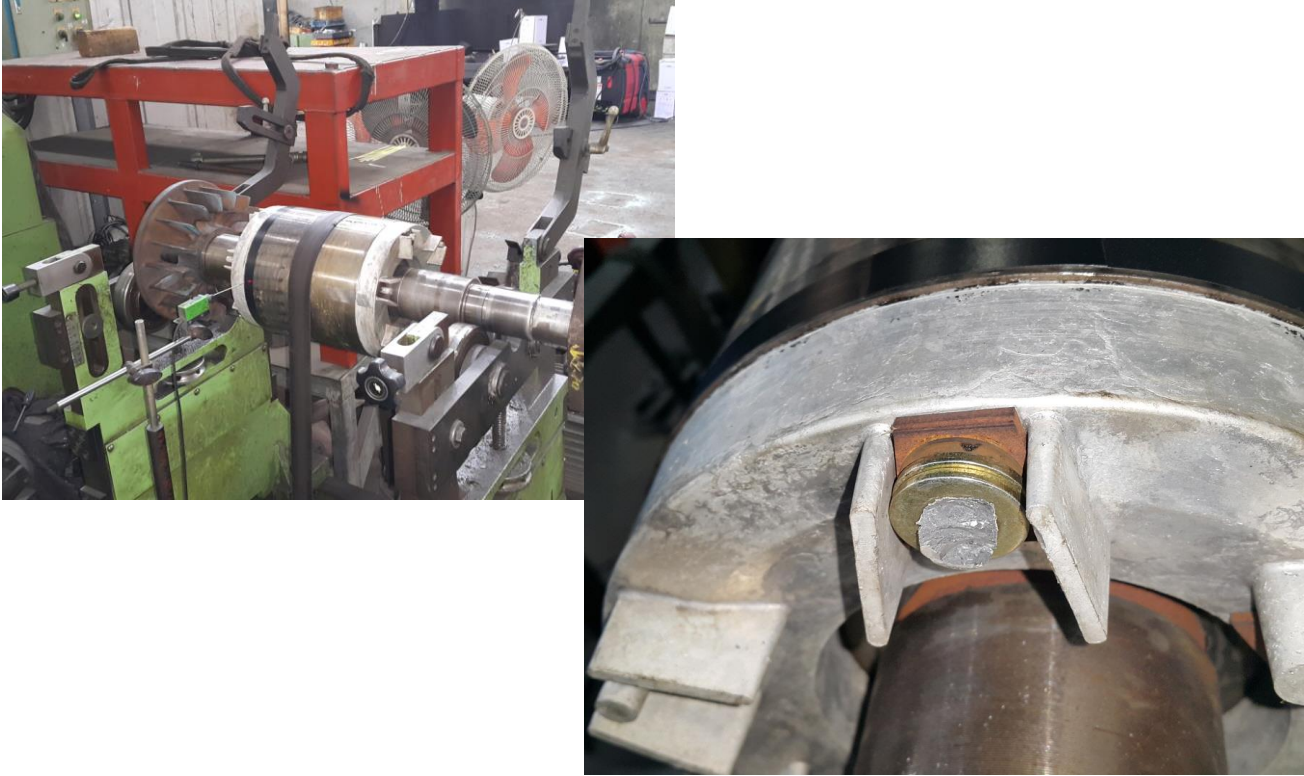
JIN YANG	작업 공정 사진
작업공정	AC MOTOR 110KW 2P REWINDING
	
STATOR권체	예열건조 및 INSULATING VARNISH DIPPING DRYING 실시
작업공정	AC MOTOR 110KW 2P REWINDING
	
BRACKET	반 부하측 HOUSING METALLIZING 연마 후 검사 1/100

JIN YANG	작업 공정 사진
작업공정	AC MOTOR 110KW 2P REWINDING
	
ROTOR	부하측 BEARING부 METALLIZING 연마 후 검사 2/100
작업공정	AC MOTOR 110KW 2P REWINDING
	
ROTOR	반 부하측 BEARING부 METALLIZING 연마 후 검사 2/100

JIN YANG	작업 공정 사진
작업공정	AC MOTOR 110KW 2P REWINDING
	
ROTOR	교정된 UNBALACE REPORT참조
작업공정	AC MOTOR 110KW 2P REWINDING
	
소모 품	교환될 BEARING 예열 실시

JIN YANG	작업 공정 사진
작업공정	AC MOTOR 110KW 2P REWINDING
	
소모 품	BEARING예열삽입 및 GREASE CHARGING
작업공정	AC MOTOR 110KW 2P REWINDING
	
조립 부품	반 부하 측 가공품 BRACKET 교환 조립 실시

JIN YANG

작업 공정 사진

작업공정

AC MOTOR 110KW 2P REWINDING



출고검사

절연저항 & 각 상별 권선저항

작업공정

AC MOTOR 110KW 2P REWINDING



출고검사

시운전 TEST 실시

JIN YANG

작업 공정 사진

작업공정

AC MOTOR 110KW 2P REWINDING



출고검사

시운전 TEST 운전 CURRENT

작업공정

AC MOTOR 110KW 2P REWINDING





상부





하부

출고검사

진동검사

JIN YANG	작업 공정 사진
작업공정	AC MOTOR 110KW 2P REWINDING
 <p>부하</p>	 <p>반부하</p>
출고검사	BEARING온도 상승검사 11시 40분 START
작업공정	AC MOTOR 110KW 2P REWINDING
 <p>부하</p>	 <p>반부하</p>
출고검사	BEARING온도 상승검사 20분 후

JIN YANG	작업 공정 사진
작업공정	AC MOTOR 110KW 2P REWINDING
 <p>부하</p>	 <p>반부하</p>
출고검사	BEARING온도 상승검사 START 55분 후
작업공정	AC MOTOR 110KW 2P REWINDING
	
Ass'y	출고검사 후

BALANCING INSPECTION REPORT

SETUP

PART NAME : AC ROTOR 2P			
CUSTOMER :			
TEST TIME : 2021. 3.27 8:27:23			
GRADE :	G 6.3	RATING SPEED :	3600 rpm
WEIGHT :	112.000 kg	TESTING SPEED :	541 rpm
DIAMETER :	230 mm	CORRECTION :	ADD
ACCEPTABLE UNBALANCE			
PLANE1 :	8.1 gr	PLANE2 :	8.1 gr

INITIAL UNBALANCE

	PLANE1	PLANE2
UNBALANCE	11.2 gr	4.9 gr
ANGLE	335 deg	29 deg
RESULT	REJECT	ACCEPT

CORRECT UNBALANCE

	PLANE1	PLANE2
UNBALANCE	4.5 gr	3.2 gr
ANGLE	8 deg	347 deg
RESULT	ACCEPT	ACCEPT

CORRECT UNBALANCE GRAPH (max = 5.0 gr)

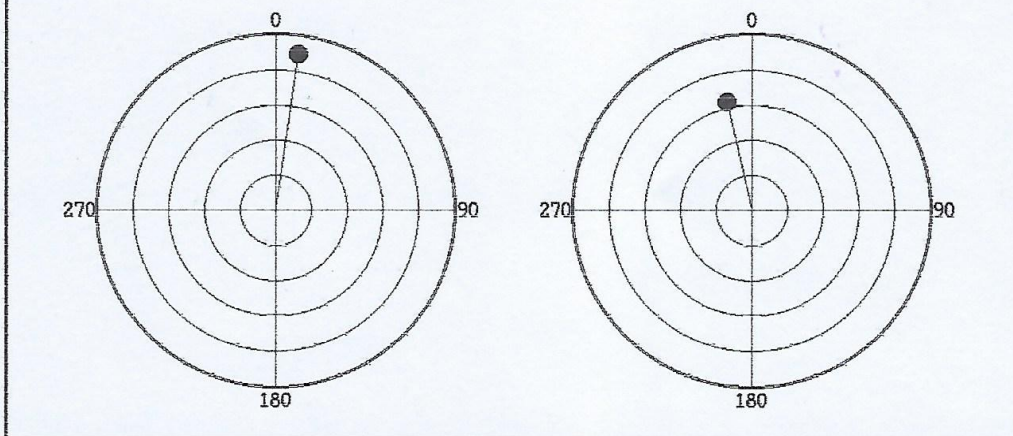

진양전기
 경남 마산시 내서읍 중리 1123-3번지
 TEL (055) - 231-9318-9
 FAX (055) - 231-9314