

작업공정사진철

고객명: (주)

공사명: 제강 TE19 CRANE BRIDGE MOTOR 동편

규격: 440V 40HP 6P 60%ED

REPAIR 내역: 분해 조립 및 불순물 CLEANSING DRYING

ROTOR REWINDING

INSULATING VARNISH DIPPING DRYING

양측 HOUSING METALLIZING 연마

BALANCING작업 UNBALANCE교정

BEARING 교환

입 출고검사 시운전 TEST 및 COLOR PAINTING



<http://jinyangmotor.com/>

KmR
ISO 9001



JIN YANG	작업 공정 사진
작업공정	권선형 MOTOR 40HP 6P 입고검사
 <p style="text-align: right;">2019/12/23 10:06 AM</p>	
Ass'y	분해 전
작업공정	권선형 MOTOR 40HP 6P 입고검사
	
STATOR권체	절연저항 & 각 상별 권선저항 동일

JIN YANG

작업 공정 사진

작업공정

권선형 MOTOR 40HP 6P 입고검사



ROTOR 권체

절연저항 & 각 상별 권선저항

작업공정

권선형 MOTOR 40HP 6P 입고검사



SLIP RING

조흔 현상

JIN YANG	작업 공정 사진
작업공정	권선형 MOTOR 40HP 6P 입고검사
 <p>2019/12/23 10:53 AM</p> <p>2019/12/23 10:53 AM</p>	
BRACKET	부하측 HOUSING 측정치 6/100로 불량
작업공정	권선형 MOTOR 40HP 6P 입고검사
 <p>2019/12/23 10:50 AM</p> <p>2019/12/23 10:50 AM</p>	
BRACKET	반 부하측 HOUSING 측정치 5/100로 불량

JIN YANG

작업 공정 사진

작업공정

권선형 MOTOR 40HP 6P 입고검사



STATOR권체

분해 후

작업공정

권선형 MOTOR 40HP 6P 입고검사



ROTOR권체

분해 후

JIN YANG

작업 공정 사진

작업공정

권선형 MOTOR 40HP 6P RECONDITION



권척

세척 실시

작업공정

권선형 MOTOR 40HP 6P RECONDITION



권척

세척 후 건조실시

JIN YANG	작업 공정 사진
작업공정	권선형 MOTOR 40HP 6P ROTOR REWINDING
	
BRACKET	부하측 HOUSING 보수 후 검사 0/100로 보수 됨
작업공정	권선형 MOTOR 40HP 6P ROTOR REWINDING
	
BRACKET	반 부하측 HOUSING 보수 후 검사 0/100로 보수 됨

JIN YANG

작업 공정 사진

작업공정

권선형 MOTOR 40HP 6P RECONDITION



권체

INSULATING VARNISH DIPPING DRYING실시

작업공정

권선형 MOTOR 40HP 6P ROTOR REWINDING



ROTOR

조립 시운전결과 이상소음과 2차 개방 회전이 되는바 2차가 상당히
문제가 있는 것으로 판단되나 소손된 위치는 찾지 못했음 재 권선 실시

JIN YANG

작업 공정 사진

작업공정

권선형 MOTOR 40HP 6P ROTOR REWINDING



ROTOR

재 권선 실시 후

작업공정

권선형 MOTOR 40HP 6P ROTOR REWINDING



ROTOR 권체

예열 건조 실시

JIN YANG	작업 공정 사진
작업공정	권선형 MOTOR 40HP 6P ROTOR REWINDING
	
ROTOR 권체	INSULATING VARNISH DIPPING DRYING실시 후
작업공정	권선형 MOTOR 40HP 6P ROTOR REWINDING
	
ROTOR 권체	BALANCING실시 및 교정된 UNBALANCE REPORT참조

JIN YANG

작업 공정 사진

작업공정

권선형 MOTOR 40HP 6P ROTOR REWINDING



출고검사

STATOR 절연저항 & 각 상별 권선저항

작업공정

권선형 MOTOR 40HP 6P ROTOR REWINDING

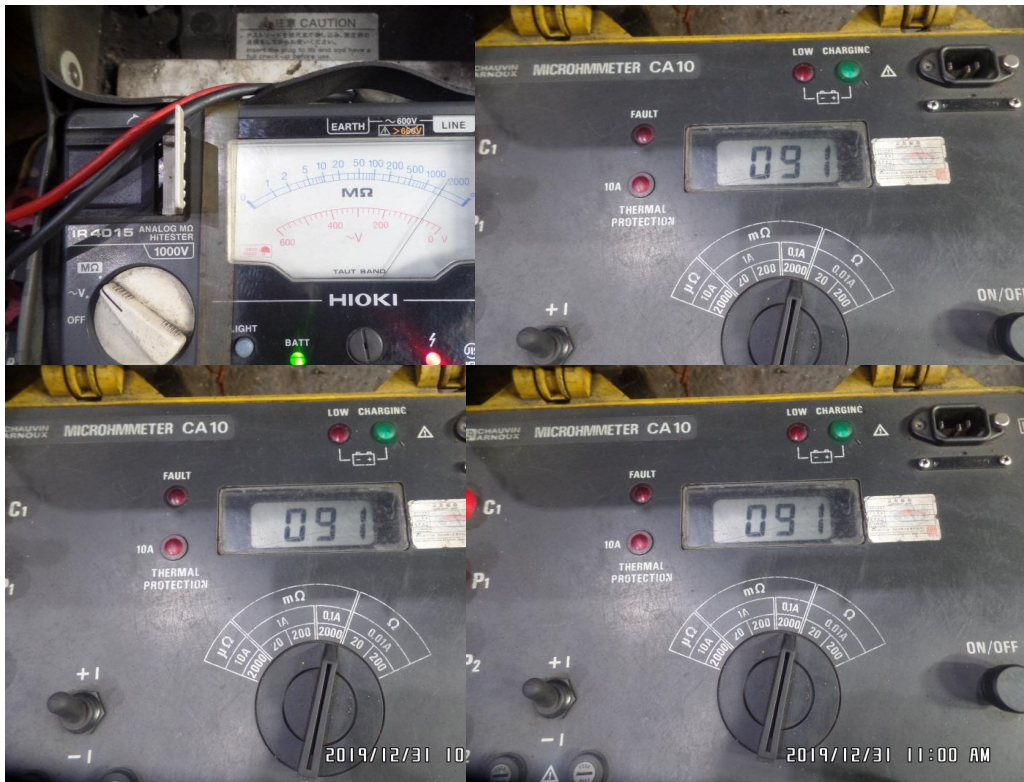

출고검사

ROTOR 절연저항 & 각 상별 권선저항

JIN YANG

작업 공정 사진

작업공정

권선형 MOTOR 40HP 6P ROTOR REWINDING



출고검사

ROTOR 2차 출력 전압



작업공정

권선형 MOTOR 40HP 6P ROTOR REWINDING



출고검사

시운전 TEST 실시

JIN YANG	작업 공정 사진
작업공정	권선형 MOTOR 40HP 6P ROTOR REWINDING
	
출고검사	시운전 TEST & CURRENT
작업공정	권선형 MOTOR 40HP 6P ROTOR REWINDING
	
Ass'y	COLOR PAINTING

BALANCING INSPECTION REPORT

SETUP

PART NAME : 권선형 ROTOR 6P40HP			
CUSTOMER : 두산중공업			
TEST TIME : 2019.12.24 15:43:24			
GRADE	: G 6.3	RATING SPEED	: 1200 rpm
WEIGHT	: 182.000 kg	TESTING SPEED	: 525 rpm
DIAMETER	: 320 mm	CORRECTION	: ADD
ACCEPTABLE UNBALANCE			
PLANE1	: 29.4 gr	PLANE2	: 29.4 gr

INITIAL UNBALANCE

	PLANE1	PLANE2
UNBALANCE	62.3 gr	50.2 gr
ANGLE	36 deg	304 deg
RESULT	REJECT	REJECT

CORRECT UNBALANCE

	PLANE1	PLANE2
UNBALANCE	20.8 gr	16.3 gr
ANGLE	221 deg	334 deg
RESULT	ACCEPT	ACCEPT

CORRECT UNBALANCE GRAPH (max = 50.0 gr)

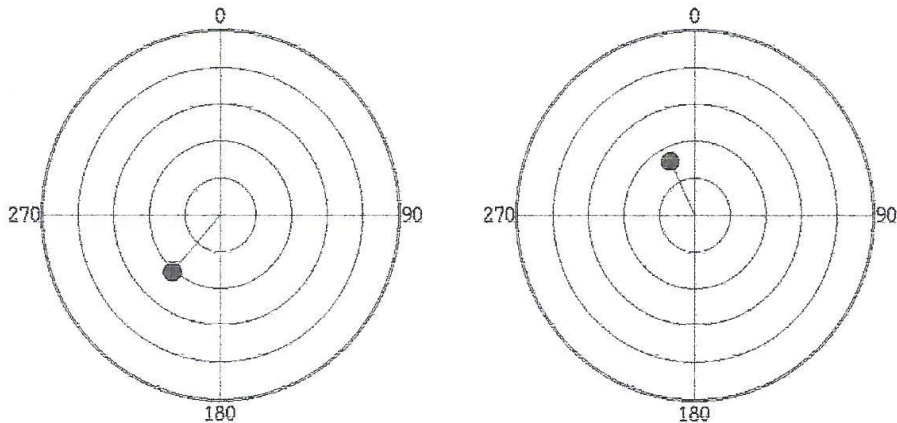

진양전기
 경남 마산시 내서읍 중리 1123-3번지
 TEL (055) - 231-9318-9
 FAX (055) - 231-9314