

작업공정사진철

고객명: 중공업 (주)

공사명: OVER HEAD CRANE 주권MOTOR수리

규격: 150HP 440V 6P 40%ED

REPAIR 내역: 분해 조립 및 불순물 CLEANSING DRYING
STATOR REWINDING
INSULATING VARNISH DIPPING DRYING
BALANCING작업 UNBALANCE교정
부하측 HOUSING METALLIZING 연마
BEARING 교환 BRUSH 재 사용
출고검사 시운전 TEST



<http://jinyangmotor.com/>

KmR
ISO 9001



JIN YANG

작업 공정 사진

작업공정

권선형 MOTOR 150HP 6P 입고검사



Ass'y

분해 전

작업공정

권선형 MOTOR 150HP 6P 입고검사



STATOR

절연저항 & 각 상별 권선저항

JIN YANG

작업 공정 사진

작업공정

권선형 MOTOR 150HP 6P 입고검사



ROTOR

절연저항 & 각 상별 권선저항

작업공정



권선형 MOTOR 150HP 6P 입고검사

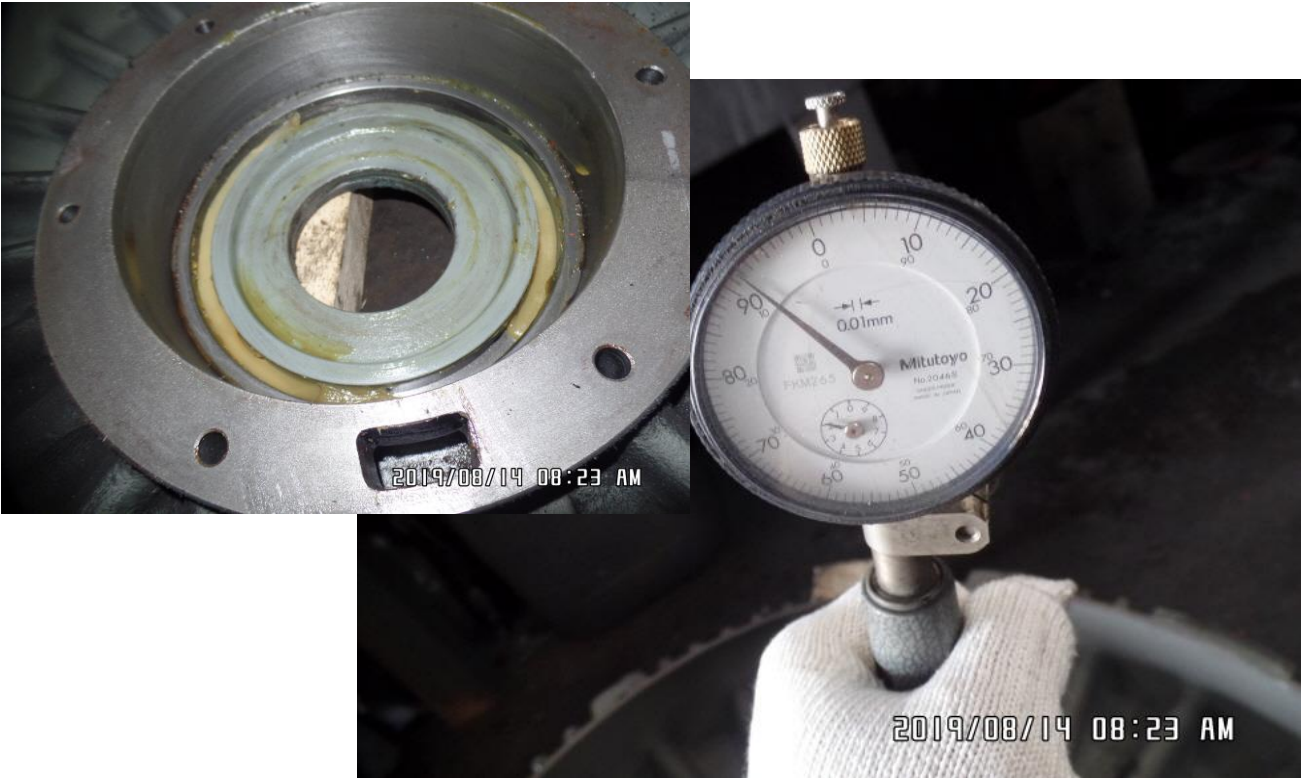

STATOR

분해 후

JIN YANG	작업 공정 사진
작업공정	권선형 MOTOR 150HP 6P 입고검사
	
ROTOR	분해 후
작업공정	권선형 MOTOR 150HP 6P 입고검사
	
BRACKET	부하측 HOUSING검사 8/100불량

JIN YANG	작업 공정 사진
작업공정	권선형 MOTOR 150HP 6P 입고검사
	
BRACKET	반 부하측 HOUSING검사 3/100으로 재 사용
작업공정	권선형 MOTOR 150HP 6P 입고검사
	
STATOR권체	스팀세척 실시

JIN YANG

작업 공정 사진

작업공정

권선형 MOTOR 150HP 6P 입고검사



ROTOR권체

세척 후 건조실시



작업공정

권선형 MOTOR 150HP 6P 입고검사



권체

세척 후 건조 실시

JIN YANG	작업 공정 사진
작업공정	권선형 MOTOR 150HP 6P 입고검사
	
STATOR	권선검사 이상
작업공정	권선형 MOTOR 150HP 6P 입고검사
	
1차 권선	소손부 확인

JIN YANG

작업 공정 사진

작업공정

권선형 MOTOR 150HP 6P 입고검사



ROTOR

권선검사 양호

작업공정

권선형 MOTOR 150HP 6P 입고검사







조흔 현상

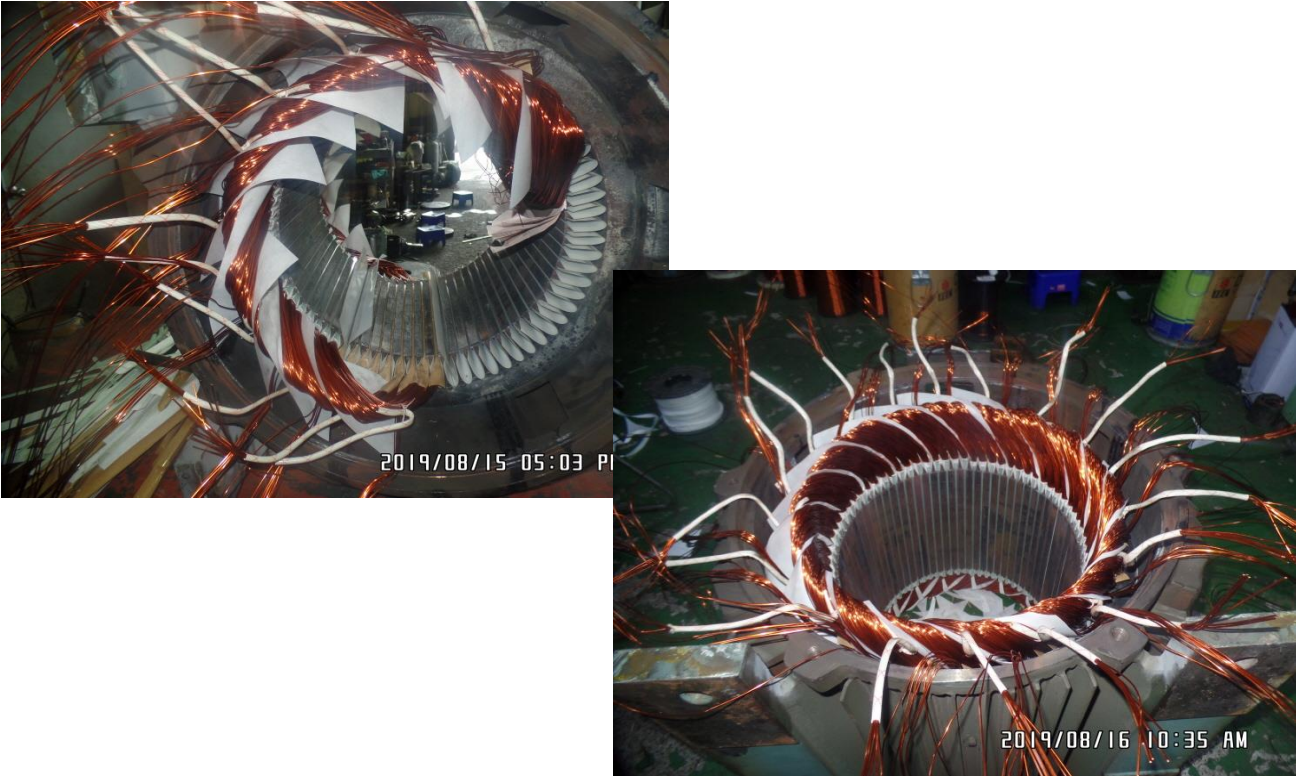

SLIP RING

동심도 가공 실시

JIN YANG	작업 공정 사진
작업공정	권선형 MOTOR 150HP 6P REWINDING
	
STATOR	재 권선 실시
작업공정	권선형 MOTOR 150HP 6P REWINDING
	
STATOR권체	1,2 차 INSULATING VARNISH DIPPING DRYING 실시

JIN YANG	작업 공정 사진
작업공정	권선형 MOTOR 150HP 6P REWINDING
	
STATOR권체	절연건조 실시 후
작업공정	권선형 MOTOR 150HP 6P REWINDING
	
ROTOR권체	URETHANE MODIFIED ACRYLIC COATING 실시

JIN YANG	작업 공정 사진
작업공정	권선형 MOTOR 150HP 6P REWINDING
	
BRACKET	부하측 HOUSING 보수 후 검사
작업공정	권선형 MOTOR 150HP 6P REWINDING
	
소모 부품	BEARING 예열 실시

JIN YANG	작업 공정 사진
작업공정	권선형 MOTOR 150HP 6P REWINDING
	
소모 부품	BEARING 예열삽입 GREASE CHARGING실시
작업공정	권선형 MOTOR 150HP 6P REWINDING
	
출고검사	STATOR 절연저항 & 각 상별 권선저항

JIN YANG

작업 공정 사진

작업공정

권선형 MOTOR 150HP 6P REWINDING



출고검사

ROTOR 절연저항 & 각 상별 권선저항

작업공정

권선형 MOTOR 150HP 6P REWINDING



출고검사

ROTOR 각 상별 출력 전압

JIN YANG

작업 공정 사진

작업공정

권선형 MOTOR 150HP 6P REWINDING



출고검사

시운전 TEST 실시

작업공정

권선형 MOTOR 150HP 6P REWINDING



출고검사

시운전 TEST & CURRENT

JIN YANG

작업 공정 사진

작업공정

권선형 MOTOR 150HP 6P REWINDING



Ass'y

출고검사 후

BALANCING INSPECTION REPORT

SETUP

PART NAME : 권선형 ROTOR 6P110KW			
CUSTOMER : 중공업			
TEST TIME : 2019. 8.17 14:52:17			
GRADE	: G 6.3	RATING SPEED	: 1200 rpm
WEIGHT	: 440.000 kg	TESTING SPEED	: 523 rpm
DIAMETER	: 400 mm	CORRECTION	: ADD
ACCEPTABLE UNBALANCE			
PLANE1	: 55.7 gr	PLANE2	: 55.7 gr

INITIAL UNBALANCE

	PLANE1	PLANE2
UNBALANCE	18.5 gr	18.0 gr
ANGLE	12 deg	288 deg
RESULT	ACCEPT	ACCEPT

CORRECT UNBALANCE

	PLANE1	PLANE2
UNBALANCE	18.5 gr	18.0 gr
ANGLE	12 deg	288 deg
RESULT	ACCEPT	ACCEPT

CORRECT UNBALANCE GRAPH (max = 50.0 gr)

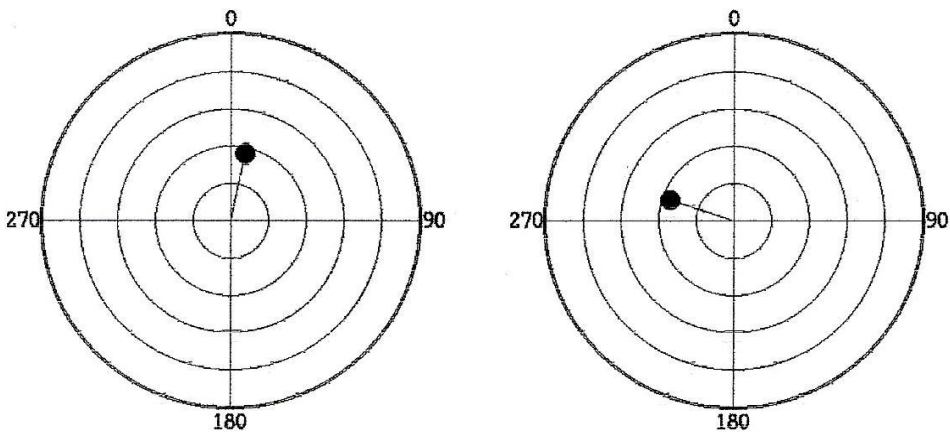

진양전기
 경남 마산시 내서읍 중리 1123-3번지
 TEL (055) - 231-9318-9
 FAX (055) - 231-9314