

작업공정사진철

고객명: 두산중공업 (주)

공사명: ROLL/CS공장 VBM(V119) TABLE MOTOR

규격: AC SERVO MOTOR 1PH8224

REPAIR 내역: 분해 및 불순물 CLEANSING DRYING
INSULATING VARNISH DIPPING DRYING
BALANCING 및 UNBALANCE교정
부하 측 HOUSING METALLIZING 연마
BEARING교환 조립
입 출고검사 및 시운전 TEST



<http://jinyangmotor.com/>



JIN YANG

작업 공정 사진

작업공정

AC SERVO MOTOR 입고검사



Ass'y

분해 전

작업공정

AC SERVO MOTOR 입고검사



권선검사

절연저항 & 각 상별 권선저항

JIN YANG

작업 공정 사진

작업공정

AC SERVO MOTOR 입고검사



Ass'y

외부 기름때 세척 후 분해 실시

작업공정

AC SERVO MOTOR 입고검사

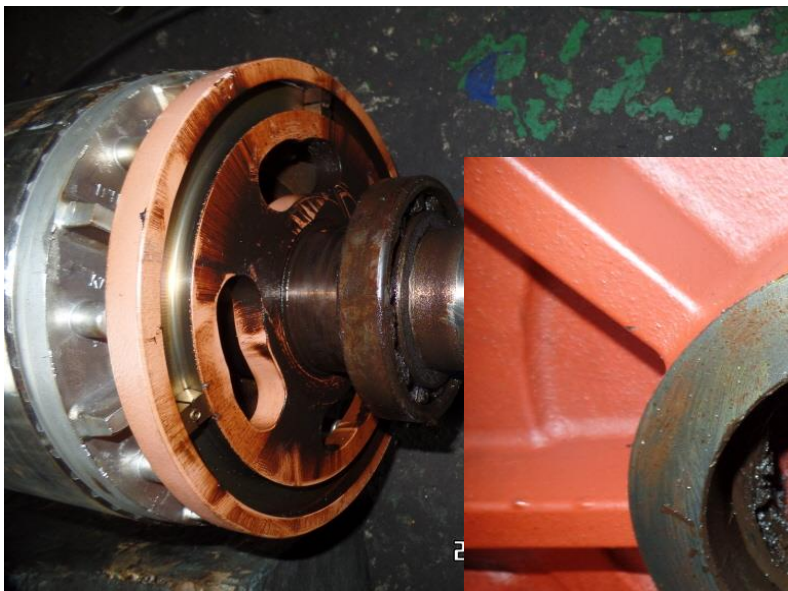

분해 실시

부하측



JIN YANG	작업 공정 사진
작업공정	AC SERVO MOTOR 입고검사



BRACKET 검사	부하측 BEARING부 HOUSING 검사치 8/100로 불량
작업공정	AC SERVO MOTOR 입고검사



BRACKET 검사	반 부하측 BEARING부 HOUSING 검사치 1/100로 재 사용
------------	--

JIN YANG	작업 공정 사진	
작업공정	AC SERVO MOTOR 입고검사	
반 부하 6216 절연B/R	 <p>2018/12/06 03:51 PM</p>	부하 6216 C4 B/R
BEARING	취의 양측 BEARING파손	
작업공정	AC SERVO MOTOR 입고검사	
	 <p>2018/12/06 04:17 PM</p>	
STATOR권체	분해 부	

JIN YANG

작업 공정 사진

작업공정

AC SERVO MOTOR 입고검사



STATOR권체

분해 후

작업공정

AC SERVO MOTOR RECONDITION



STATOR권체

세척 실시

JIN YANG

작업 공정 사진

작업공정

AC SERVO MOTOR RECONDITION



STATOR권체

세척 후 실시



작업공정

AC SERVO MOTOR RECONDITION



조립 부품

세척 실시

JIN YANG	작업 공정 사진
작업공정	AC SERVO MOTOR RECONDITION
	
BRACKET 검사	반 부하측 HOUSING 보수 후 검사(1/100)
작업공정	AC SERVO MOTOR RECONDITION
	
ROTOR	BALANCING실시 UNBALACE교정

JIN YANG	작업 공정 사진
작업공정	AC SERVO MOTOR RECONDITION



조립부품	반 부하측 절연BEARING & 부하측 일반C4급
작업공정	AC SERVO MOTOR RECONDITION



BEARING	예열 실시
---------	-------

JIN YANG

작업 공정 사진

작업공정

AC SERVO MOTOR RECONDITION

부하 6216C4



2018/12/10 09:

반부하 절연 BEARING 6216C4



2018/12/10 09:32 AM

BEARING

예열삽입 실시

작업공정

AC SERVO MOTOR RECONDITION



2018/12/10 01:25 PM



2018/12/10 01:23 PM



2018/12/10 01:23 PM



2018/12/10 01:24 PM

출고검사

절연저항 & 각상별 권선저항

JIN YANG

작업 공정 사진

작업공정

AC SERVO MOTOR RECONDITION



출고검사

시운전 TEST 실시

작업공정

AC SERVO MOTOR RECONDITION



Ass'y

출고검사 후 COLOR PAINTING

시운전 TEST 운전 MONITORING

File Edit Start up Operator control Diagnostics Options Help

PC has Master Control for Drive A => Only term, 663 (pulse enable) and term, 65,x (control enable) are evaluated !!!



speed-controlled operation

Reference speed rpm
correspond to V input voltage

Rotational direction 

Clockwise (positive)
 Counter-clockwise (nega)

Torque: %

 Stop with space bar ! 

Start (F9) (Space bar) Stop (Space bar)

Start via signal Override: rpm

Traversing dialog

ok? Controller enable PC (F8)
 Pulse enable module term, 663 Speed: rpm Actual = rpm
 Controller enable term, 65 Torque: Nm
 Ramp-function generator enable Parameter set: Motor:
 Pulse enable NE term, 63/48 Capacity utili: A Motor current: A
 Contr. enable NE term, 64/63 Overview status

Torque-generating curren A(rms)
DC link voltage V(pk)

STOP at the program change Overview status

Press F1 to display Help.

2018-12-10 오후 1:50:22

BALANCING INSPECTION REPORT

SETUP

PART NAME : SERVO ROTOR115KW			
CUSTOMER : 두산중공업			
TEST TIME : 2018.12.10 8:40:41			
GRADE :	G 6.3	RATING SPEED :	1350 rpm
WEIGHT :	172.000 kg	TESTING SPEED :	523 rpm
DIAMETER :	290 mm	CORRECTION :	ADD
ACCEPTABLE UNBALANCE			
PLANE1 :	26.4 gr	PLANE2 :	26.4 gr

INITIAL UNBALANCE

	PLANE1	PLANE2
UNBALANCE	57.7 gr	28.4 gr
ANGLE	39 deg	187 deg
RESULT	REJECT	REJECT

CORRECT UNBALANCE

	PLANE1	PLANE2
UNBALANCE	8.9 gr	13.9 gr
ANGLE	337 deg	143 deg
RESULT	ACCEPT	ACCEPT

CORRECT UNBALANCE GRAPH (max = 50.0 gr)

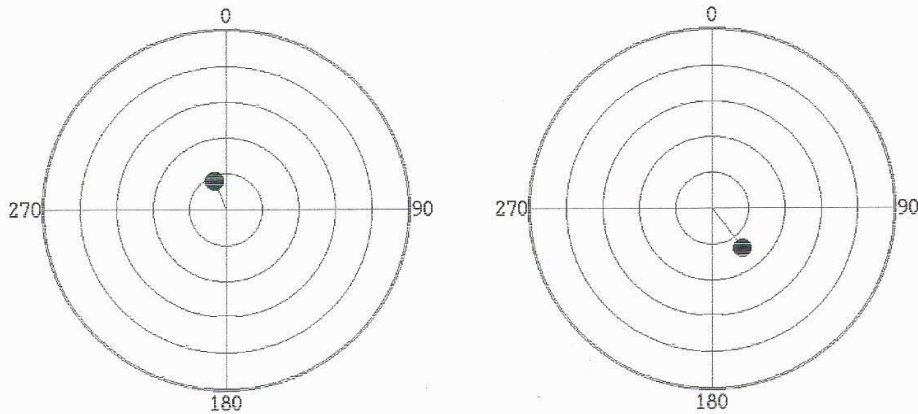

진 향 전 기

경남 마산시 내서읍 중리 1123-3번지

TEL (055) - 231-9318-9

FAX (055) - 231-9314