

작업공정사진철

고객명 : 고려강재장

공사명 : DC MOTOR RECONDITION 2대 외

규격 : HOIST MOTOR 200HP

REPAIR 내역 : 분해 조립 및 불순물 CLEANSING DRYING
INSULATING VARNISH DIPPING DRYING
COMMUTATOR 동심도 가공 및 UNDERCUTTING
양측 HOUSING METALLIZING 연마
BEARING 및 BRUSH 교환
BALANCING 및 UNBALANCE 교정
BLOWER 보수
입 출고검사 및 시운전 TEST



<http://jinyangmotor.com/>

KmR
ISO 9001



JIN YANG

작업 공정 사진

작업공정

DC MOTOR 200HP 입고검사 A MOTOR



Ass'y

분해 전

작업공정

DC MOTOR 200HP 입고검사 A MOTOR

ARMATURE
절연저항



2018/08/05 08:42

ARMATURE
권선저항



2018/08/05 08:42 AM

FIELD
절연저항



2018/08/05 08:41 AM

FIELD
권선저항
병렬일때



2018/08/05 08:41 AM

권선검사

절연저항 & 권선저항

JIN YANG

작업 공정 사진

작업공정

DC MOTOR 200HP 입고검사 A MOTOR



권체

분해 실시

작업공정

DC MOTOR 200HP 입고검사 A MOTOR



권체

분해 후 권체

JIN YANG

작업 공정 사진

작업공정

DC MOTOR 200HP 입고검사 A MOTOR



COMMUTATOR

조흔 현상





작업공정



DC MOTOR 200HP 입고검사 A MOTOR



BEARING부

GREASE CHARGING주기가 긴 것으로 보임 BEARING과열 현상

JIN YANG	작업 공정 사진
작업공정	DC MOTOR 200HP 입고검사 A MOTOR
	
BRACKET	부하측 HOUSING 측정치 7/100로 불량
작업공정	DC MOTOR 200HP 입고검사 A MOTOR
	
BRACKET	반 부하측 HOUSING 측정치 5/100로 불량

JIN YANG	작업 공정 사진
작업공정	DC MOTOR 200KW RECONDITION
	
조립 부품	세척 실시
작업공정	DC MOTOR 200KW RECONDITION
	
조립부품	세척 실시

JIN YANG

작업 공정 사진

작업공정

DC MOTOR 200KW RECONDITION



권체

세척 후 건조 실시

작업공정

DC MOTOR 200KW RECONDITION



COMMUTATOR

세척 건조 후 검사 상당한 문제가 있었던 것으로 짐작 됨

JIN YANG

작업 공정 사진

작업공정

DC MOTOR 200KW RECONDITION

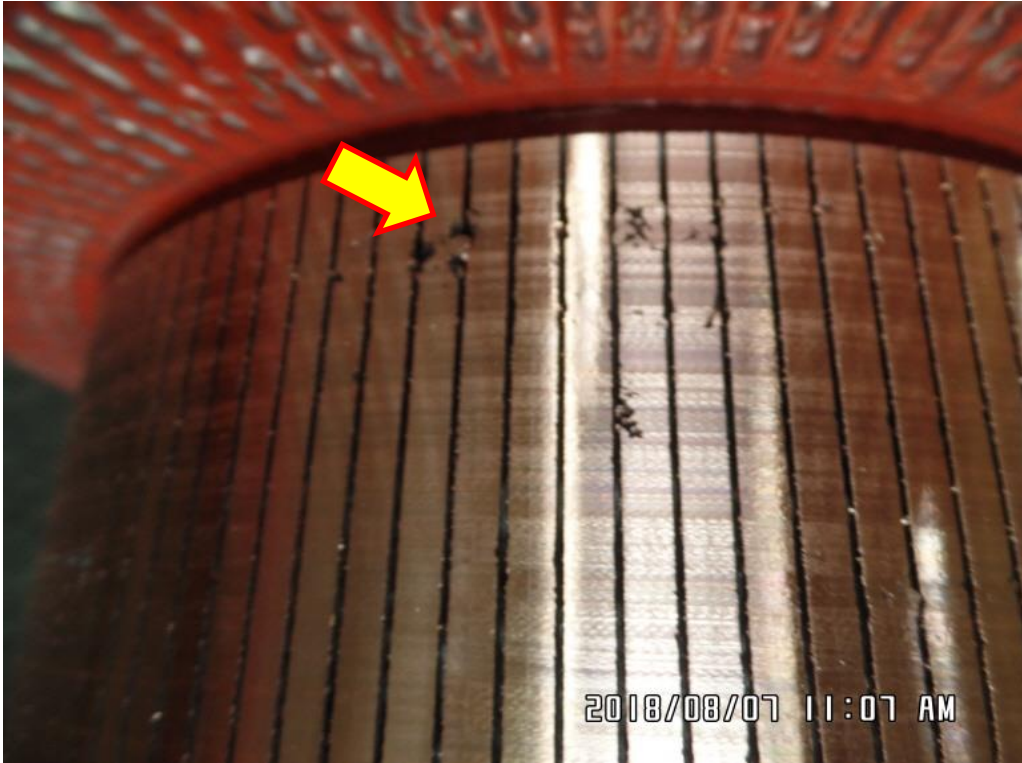

COMMUTATOR

동심도가공 후 SPARK SHORT상태가 여러곳 있음

작업공정

DC MOTOR 200KW RECONDITION



COMMUTATOR

홈파기 및 UNDERCUTTING 실시

JIN YANG	작업 공정 사진
----------	----------

작업공정	DC MOTOR 200KW RECONDITION
------	----------------------------



BRACKET	부하측 HOUSING 보수 후 검사
---------	---------------------

작업공정	DC MOTOR 200KW RECONDITION
------	----------------------------



BRACKET	반 부하측 HOUSING 보수 후 검사
---------	-----------------------

JIN YANG

작업 공정 사진

작업공정

DC MOTOR 200KW RECONDITION



권체

URETHANE MODIFIED ACRYLIC COATING 실시

작업공정

DC MOTOR 200KW RECONDITION



소모품

교환될 구매부품

JIN YANG

작업 공정 사진

작업공정

DC MOTOR 200KW RECONDITION

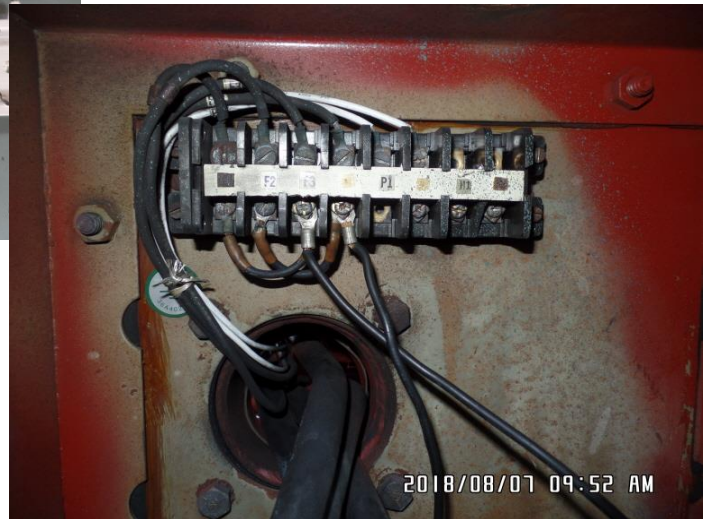
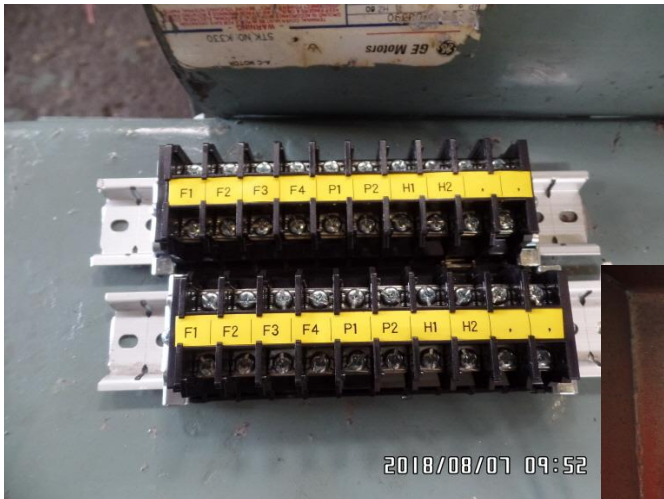

소모품

TERMINAL BLOCK교환

작업공정

DC MOTOR 200KW RECONDITION



ARMATURE

BALANCING실시 UNBALACE교정

JIN YANG

작업 공정 사진

작업공정

DC MOTOR 200KW RECONDITION



소모부품

BEARING & BRUSH교환 실시

작업공정

DC MOTOR 200KW RECONDITION

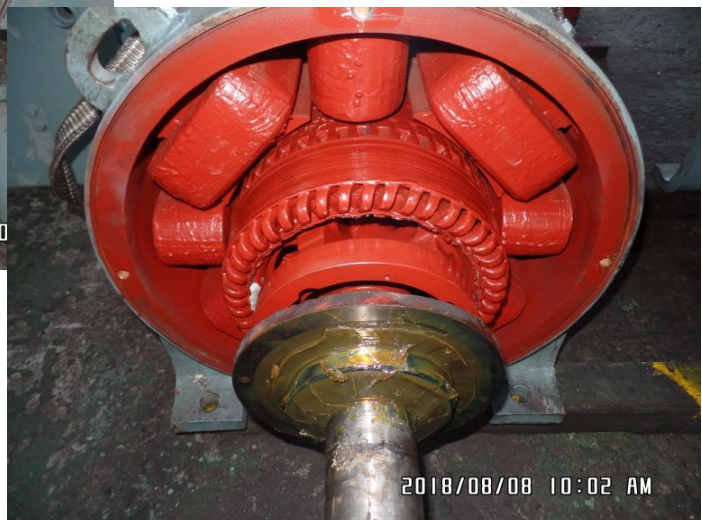

소모부품

BEARING교환 실시

JIN YANG

작업 공정 사진

작업공정

DC MOTOR 200KW RECONDITION

ARMATURE
절연저항



ARMATURE
권선저항



FIELD
절연저항



FIELD
권선저항



출고검사

절연저항 & 권선저항

작업공정

DC MOTOR 200KW RECONDITION



출고검사

시운전 TEST실시

JIN YANG

작업 공정 사진

작업공정

DC MOTOR 200KW RECONDITION



출고검사

시운전 MONITORING

작업공정

DC MOTOR 200KW RECONDITION



Ass'y

출고검사 후

BALANCING INSPECTION REPORT

SETUP

PART NAME : DC ROTOR 200HP A			
CUSTOMER : 세중			
TEST TIME : 2018. 8. 8 8:51:29			
GRADE	: G 6.3	RATING SPEED	: 1700 rpm
WEIGHT	: 426.000 kg	TESTING SPEED	: 601 rpm
DIAMETER	: 330 mm	CORRECTION	: ADD
ACCEPTABLE UNBALANCE			
PLANE1	: 45.7 gr	PLANE2	: 45.7 gr

INITIAL UNBALANCE

	PLANE1	PLANE2
UNBALANCE	34.0 gr	20.4 gr
ANGLE	160 deg	181 deg
RESULT	ACCEPT	ACCEPT

CORRECT UNBALANCE

	PLANE1	PLANE2
UNBALANCE	21.0 gr	23.6 gr
ANGLE	155 deg	178 deg
RESULT	ACCEPT	ACCEPT

CORRECT UNBALANCE GRAPH (max = 50.0 gr)

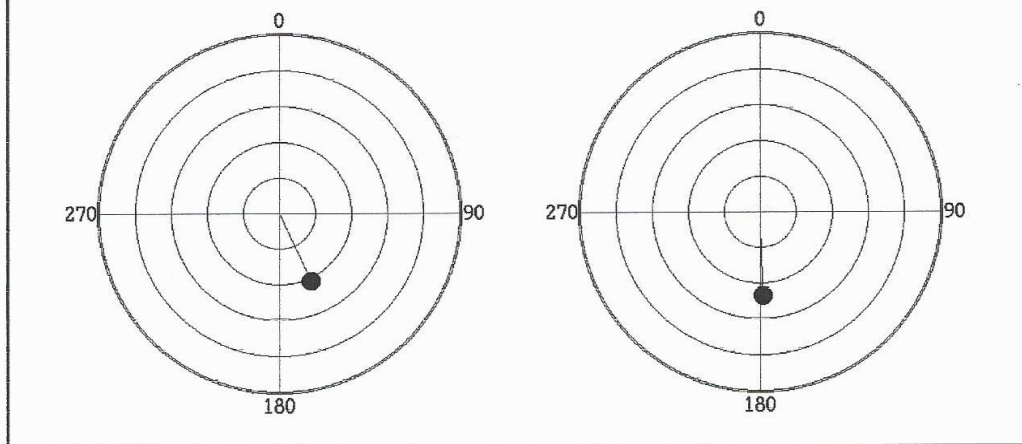

진양전기

경남 마산시 내서읍 중리 1123-3번지

TEL (055) - 231-9318-9

FAX (055) - 231-9314

BALANCING INSPECTION REPORT

SETUP

PART NAME : DC ROTOR 200HP B			
CUSTOMER : 세종			
TEST TIME : 2018. 8. 8 13:38:50			
GRADE	: G 6.3	RATING SPEED	: 1700 rpm
WEIGHT	: 426.000 kg	TESTING SPEED	: 601 rpm
DIAMETER	: 330 mm	CORRECTION	: ADD
ACCEPTABLE UNBALANCE			
PLANE1	: 45.7 gr	PLANE2	: 45.7 gr

INITIAL UNBALANCE

	PLANE1	PLANE2
UNBALANCE	14.1 gr	21.8 gr
ANGLE	152 deg	207 deg
RESULT	ACCEPT	ACCEPT

CORRECT UNBALANCE

	PLANE1	PLANE2
UNBALANCE	14.1 gr	21.8 gr
ANGLE	152 deg	207 deg
RESULT	ACCEPT	ACCEPT

CORRECT UNBALANCE GRAPH (max = 50.0 gr)

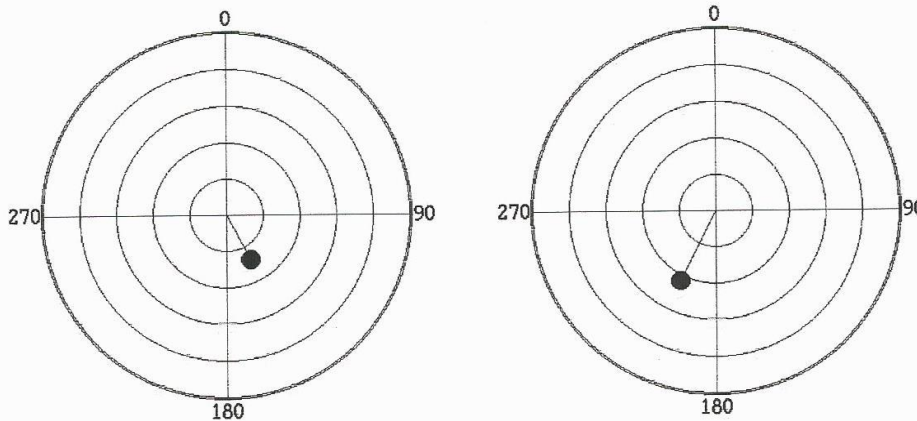

진양전기
 경남 마산시 내서읍 중리 1123-3번지
 TEL (055) - 231-9318-9
 FAX (055) - 231-9314

